

Reversible Vibratory Plates BPR25/40 BPR25/40D



The transport wheels allow for one-person movement around the jobsite.



The Vulcolan mat helps avoid damage to paving stone surfaces.



Technical Specifications

BPR25/40 BPR25/40D

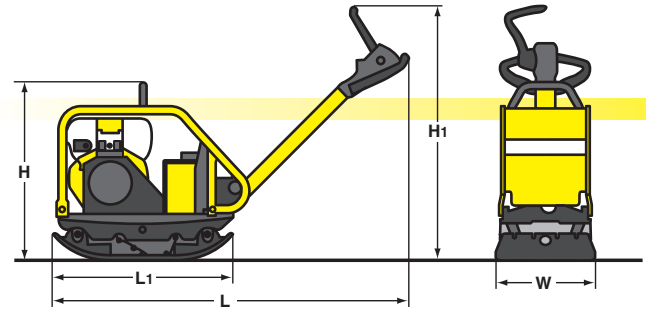

Shipping dimensions

in cubic feet (m³)

BPR25/40 22 (0.624)

BPR25/40D 22 (0.624)

Standard Equipment

- Hydraulic travel lever adjustment
- Vibration dampened steering rod
- Height adjustable steering rod
- Steering rod lockable in transport and working position
- Vibration and throttle regulation on the steering rod
- Highly wear resistant base plate with reinforced edges
- Fully protected V-belt
- Reinforced centrifugal clutch
- Automatically adjusting v-belt pulley
- Semi-automatic decompression (BPR25/40D)
- Large-volume dry air filter with cyclone-type precleaner (BPR25/40)
- Maintenance-free transistor ignition (BPR25/40)
- Recoil starter

Optional Equipment

- Vulcolan mat
- Transport Wheels
- Service Kit

Dimensions

inches (mm)	H	H ₁	L	L ₁	W
BPR25/40	25.9 (660)	34.3 (870)	57.5 (1460)	25.6 (650)	15.7 (400)
BPR25/40D	29.1 (740)	34.3 (870)	57.5 (1460)	25.6 (650)	15.7 (400)

Technical data

Weights

Basic weight	lbs (kg)	238 (108)	278 (126)
Operating weight	lbs (kg)	245 (111)	284 (129)

Dimensions

Dimensions	see sketch	see sketch
------------------	------------	------------

Driving characteristics

Working speed max	ft/min (m/min)	82 (25)	82 (25)
Max gradeability	%	30	30

Drive

Engine manufacturer	Honda	Hatz
Type	GX 160	1B20
Cooling	air	air
Number of cylinders	1	1
Performance ISO 9249	4.8 (3.6)	4.2 (3.1)
Speed	3600	3000
Fuel	gasoline	Diesel

Exciter System

Frequency	vpm (Hz)	5100 (85)	5100 (85)
Centrifugal Force	lbs (kN)	5620 (25)	5620 (25)

Capacities

Fuel	gal (l)	1 (3)	1 (3)
------------	---------	-------	-------

Technical modifications reserved. Machine may be shown with options.