



M 350 H

EL VEHICULO MULTIUSOS QUE FACILITA TU TRABAJO
THE TOOL-CARRIER THAT MAKES YOUR WORK EASIER
MULTISERVICE DAS VIELSEITIGE FAHRZEUG FÜR DIE KOMMUNE UND DEN DIENSTLEISTER
LE VEHICULE MULTISERVICE QUI FACILITE VOTRE TRAVAIL

EURO 5



www.ausa.com

AUSA Center, S.L.
Ctra. de Vic Km 2.8
08243 Manresa
BARCELONA (ESPAÑA)
Tel.: +34 93 874 73 11
E-mail: ausa@ausa.com
www.ausa.com



AUSA Madrid Pol. Ind. Coslada - C. Marconi 15-17, 28823 Coslada - MADRID (ESPAÑA) - Tel.: +34 91 669 00 06 - E-mail: ausa.madrid@ausa.com
AUSA France Z.I. Saint Charles - Rue de Zürich, 66000 PERPIGNAN (FRANCE) - Tel.: +33 (0) 4 68 54 38 97 - E-mail: ausa.france@ausa.com
AUSA Deutschland Tel.: +49 (0) 2384 9889905 - E-mail: ausa.deutschland@ausa.com
AUSA UK Tel.: +44 (0) 7970639988 - E-mail: ausa.uk@ausa.com
AUSA Brasil Avenida Belizario Ramos 2276 - Lages - SC, 88506-000 (BRASIL) - Tel.: +55 11 9 8786 6014 - E-mail: ausa.brasil@ausa.com
AUSAMéxico Calzada Vallejo 725 Del. Gustavo A. Madero - 07750 México D.F. (MÉXICO) - Tel.: +52 (55) 21669276 - E-mail: ausa.mexico@ausa.com
AUSA U.S. CORP. Tel.: +1 (917) 328 0770 - E-mail: ausa.us@ausa.com
AUSA Beijing Rep. Office Room 403, Moma Building, N.199 - Chaoyang bei road, Chaoyang District - 100026 BEIJING (CHINA)
Tel.: +86 10 8598 7386 - E-mail: ausa.china@ausa.com

M 350 H

AUSA

www.ausa.com

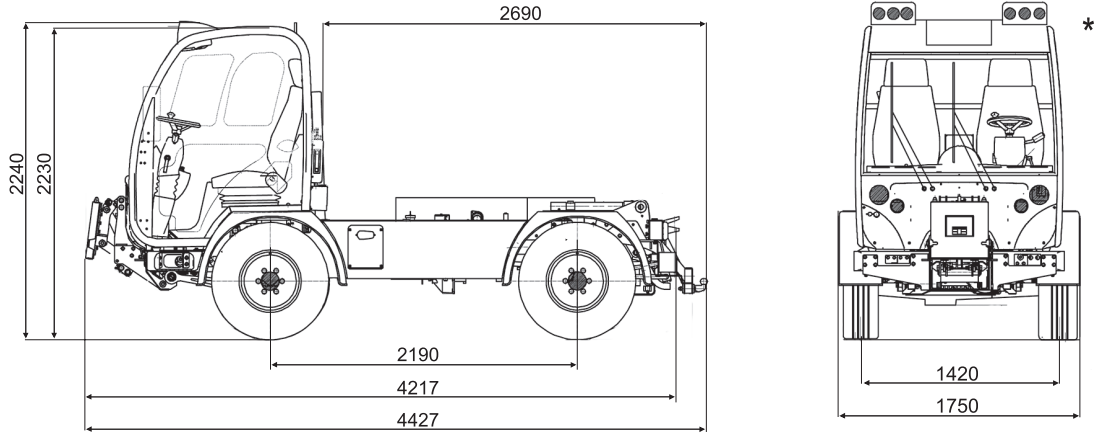

TECHNICAL SPECIFICATIONS

Load capacity (Kg)	3500	Gradient negotiable (with full load)	38%
Load capacity with load bed (Kg)	3000	Brakes	Service
Hooper capacities (l)	Levelled		Hydraulic pump with servo brake, discs on front wheels and drum on rear wheels Optional ABS+EDB (Standard for 62 km/h)
	Heaped		
Engine	Make	VOLKSWAGEN	Parking
	Type	2.0 TDI EURO 5	Steering
	Power (Kw - Cv)	75 - 102 (3000 rpm)	Suspension
	N. of Cylinders	4	Front suspension helicoidal spring & hydraulic damper Rear suspension parabolic leaf spring & Hydraulic damper
	Cooling	Liquid	Attack
	Fuel	Diesel	Obstruction angle
	Fuel capacity (l)	85	Departure angle
Transmission	2 hydrostatic gear and 2 gear speed-reducer	Weight (Kg)	Unloaded weight * 3170 - 4205 (1825-2400 front axle ; 1470-1805 rear axle) Gross weight 6400 (2650 front axle ; 3750 rear axle)
		Hydraulic delivery	Service pump 1 (47 l/min); Service pump 2 (35 l/min); Steering pump (15 l/min)
Groud speed (Km/h)	Limited to 40 / Optional 62 Km/h available in certain countries	Hydraulic power circuits	4 front and 2 rear: Max. flow 47 l/min; Max pressure 230 (p.1) / 180 (p.2) bar @ 2.200 rpm
Traction	4x2 4x4 disconnectable with FullGrip®		

* Load or dimension data may change due to optional equipment

STANDARD EQUIPMENT

Closed cabin with heating	Rotating beacon with telescopic support of 450 mm
Electronic boost of rpm engine	Wiring for transceiver set
Doors with panning visibility	Radio
Heated rear mirrors elect. adjustable	Approved lighting system
Driver seat with pneumatic suspension	Beacons elect. adjustable
Passenger seat with mechanic suspension	Wheel wrench

OPTIONAL EQUIPMENT

Front plate for attachments	Service pump 1 (60 l/min); S. P2 (14 l/min); Service pump 3 (46 l/min-15 l/min used by hydraulic steering)	ABS + EBD and load sensitive device to adjust braking force. (standard for 62 Km/h)	Towing hitch "Rockinger" with electric socket
Semi-chassis "LINKSystem®" for quick coupling and removal of optional attachments	Hyd. circuits: 5 front and 3 rear: Max. flow 60 l/min;	Air conditioning / Spare wheel	All terrain, multipurpose or wide tyres option
Tipping body	Max pressure 230 p.1) / 180 (p.2) bar @ 2.200 rpm	Towing hitch ball (50 mm) with electric socket	Passenger seat with pneumatic suspension 4x2 rear locking differential

ADITIONAL ACCESSORIES

Salt spreader capacity	Hydraulic powered with easy removable system. Capacity: 1.4 m3
Snow-blade	Width 2.000 mm with hydraulic swivel
Snow-blade type V	Width 2.400 mm with hydraulic regulation
Snow sweeper broom	width 2.000 mm
Front and lateral reach arm brush-cutter	reaching distance up to 3.5 m with rear and removable counterweight (included Front suspension)
Aerial working man-lift platform MOVEX	Working height 15,3 m; load capacity 200kg./2 persons; included hydraulic cylinders jacks
Steel and removable tank	For suction and transport sludge and septic tank emptying .
Hydraulic articulated crane equipment	With manual controls / With radio control commands / with homologated aerial work platform
Water pressure cleaning unit 1	Plastic tank. Removable. Capacity 2.000 l. Spraying bar width 2.000 mm
Water pressure cleaning unit 2	Aluminium tank. Removable. Capacity 2.200 l. Telescopic spraying bar. Bar spraying width upto 2.500 mm.
Three-way hydraulic tipping body	With fold-down and removable sides & tailgate 2.640 x 1.600 x 300 mm
Cabin protection extension	In tipping body 300 mm height
Extension mesh in tipping body	(3 sides 400 mm; height) and support on top of cabin for long loads

MKT22023.04/04.2014

AUSA reserves the right to make any changes in the specifications without prior notice.