



HPT 10 XM

HPT 10 XE

HPT 20 FL

HPT 25

HPT 25 GA

HPT 25 ST

HPT 30

HPT Technical Data

Hand pallet truck and scissor lift truck



Technical Data and equipment			HPT 25	HPT 25 ST	HPT 25 GA	HPT 30	HPT 20 FL	HPT 10 XM	HPT 10 XE
Q	Capacity	Kg	2500	2500	2500	3000	2000	1000	1000
	Truck weight	Kg	63	69	63	67	71	104	141
l	Standard fork length	mm	1150	1150	1150	1150	1150	1150	1150
c	Load centre	mm	575	575	575	575	575	575	575
L	Overall length	mm	1550	1550	1550	1550	1550	1526	1685
∅	Steer wheels	mm	200 x 50	200 x 50	200 x 50	200 x 50	200 x 50	200 x 50	200 x 50
∅	Tandem load rollers	mm	82 x 60	82 x 60	82 x 60	82 x 60	55 x 58	-	-
∅	Single load rollers	mm	82 x 82	82 x 82	82 x 82	82 x 82	-	82 x 82	82 x 82
W _a	Turning radius	mm	1385	1385	1385	1385	1385	1340	1445
A _{st}	Working aisle width	mm	1835	1835	1835	1835	1835	1779	1948
b ₁	Width over forks	mm	525	525	525	525	525	540	540
e	Fork width	mm	150	150	150	150	160	160	160
h ₁₃	Lowered height	mm	85	85	85	85	56,5	85	85
h ₃	Lift height	mm	200	200	200	200	170	800	800

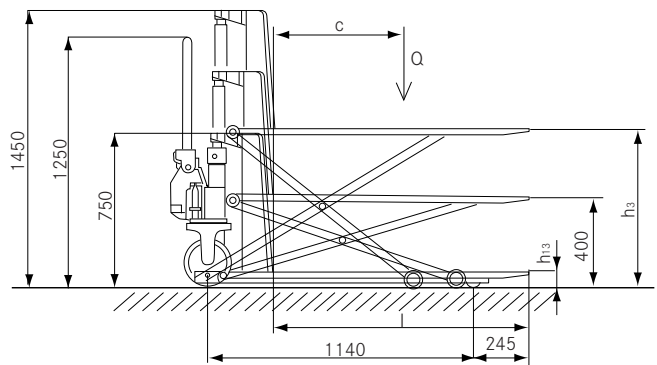

HPT 10 XM – Manual scissor lift truck.

Capacity 1.000 kg.

The HPT 10 XM manual scissor lift truck combines the function of a lifting table with the helpfulness and versatility of a hand pallet truck. The operator friendly work height (up to 800 mm) protects the back when order picking, putting parts into stock, or when loading vehicles. For added safety, automatic supports stabilise the truck from 400 mm lift heights and above.

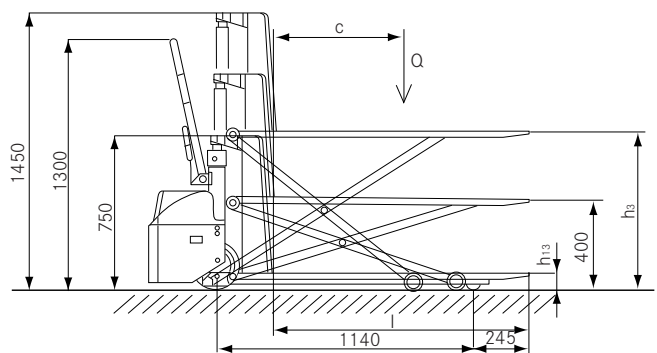
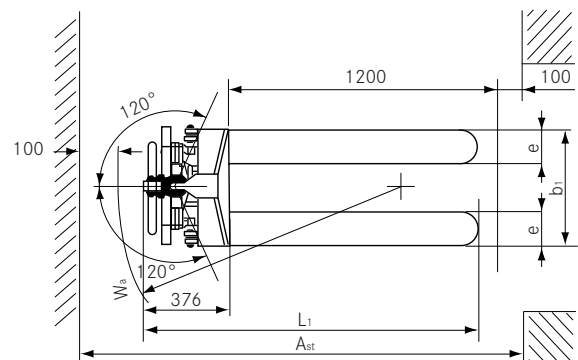

HPT 10 XE – Electro-hydraulic scissor lift truck.

Capacity 1.000 kg.

The HPT 10 XE scissor lift truck comes with an electro-hydraulic lift fitted with a powerful 1.6 kW lift motor and 12 V/60 Ah battery. The working surface (loading surface) can be adjusted quickly and effortlessly to the optimal work height at the push of a button. This not only makes using the truck child's play – putting goods into stock, order picking, loading, etc. – but also protects the operator's back. For even greater safety, automatic supports stabilise the truck from 400 mm lift heights and above.

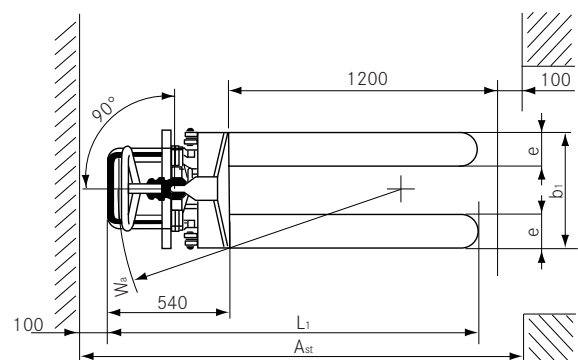



HPT 25/HPT 30 – Hand pallet truck.

Capacity 2.500 kg/3.000 kg.

The HPT 25 and HPT 30 hand pallet trucks stand out from the crowd thanks to their high quality build and user friendly design. These versatile all-rounders are available in 2.5 and 3.0 tonne capacities respectively, with various fork lengths and widths. Further individual equipment options round off the range.

Tiller.

- Ergonomic grip for fatigue free operation.
- A maximum steering lock of 205° gives excellent manoeuvrability, even in the tightest of spaces – such as loading and unloading lorries.

Frame.

- Warp resistant steel structure is capable of high loadings due to optimised fork geometry.
- Powder coated surfaces for high resistance to abrasion.
- Additional entry and exit rollers make it easier to pick up pallets from the side.

Hydraulics.

- Compact hydraulic unit with overload protection.
- Sensitive regulation of the lowering speed.
- Optional quick-lift function up to 250 kg.

Wheels and tyres.

- Nylon tyres for low rolling resistance and low steering effort.
- Polyurethane tyres for low running noise and low steering effort.
- Solid rubber tyres for quiet running and optimal floor adhesion.
- Tandem load rollers permit easier running on uneven floors.
- Option of service and parking brake.

HPT 20 FL – Flat fork pallet truck.

Capacity 2.000 kg.

With flat forks, the HPT 20 FL achieves a minimum floor height of just 56.5 mm, making it suitable for specialist low pallets, displays and packages. The forward tapered fork tips act as a skid plate and facilitate side entry into the pallet.

HPT 25 GA/HPT 25 ST – Corrosion protected hand pallet truck.

Capacity 2.500 kg.

The HPT 25 GA is a galvanised version of the hand pallet truck as required in damp or cool operating conditions. This makes it ideal for agriculture, gardening businesses, market halls, or in harbour areas. The HPT 25 ST is made of INOX stainless steel (AISI 304) as required in areas of highest hygiene, making it ideal for pharmaceutical, foodstuffs and chemical industries. The electro-polished surfaces are dirt repellent and easy to clean, whilst the pump body (made of marine bronze) protects the hydraulic system from corrosion – even in high humidity. The totally enclosed roller bearings ensure optimal lubrication regardless of the application.



Your contact

STILL GmbH
Berzeliusstraße 10
D-22113 Hamburg
Telephone: +49 (0)40/73 39-20 00
Telefax: +49 (0)40/73 39-20 01
info@still.de

For further information please visit:
www.still.eu

STILL Materials Handling Ltd.
Aston Way, Leyland
Lancashire PR26 7UX
Telephone: +44 (0)1772 644300
Telefax: +44 (0)1772 644303
info@still.co.uk

For further information please visit:
www.still.co.uk

