

Chain Lubrication

Automated Lubrication Systems for Oil & Grease



- All chain sizes
- All chain speeds
- All operating conditions

Lincoln Company Profile



Our Experience

Lincoln was established in 1910 and is the long-standing world leader in grease lubrication systems and equipment. Decades of business experience have provided us with a high level of expertise and know-how within the lubrication system industry. As a pioneer in the industry, we will continue being a trendsetter confidently providing our customers with the best lubrication system solutions in both price and quality.



Our Service

Our customer service includes the consulting, engineering and planning of customer-oriented systems for all applications, the manufacturing of standard components such as pumps, metering devices or control equipment, the installation and start up of lubrication systems on site in all parts of the world, as well as the customer training, and after-market service.

Our Quality

Our certified Quality Management System according to DIN EN ISO 9001, our expertise, consulting qualities and inventiveness, lead the way for future customer-oriented, economical and intelligent solutions.



Our Product

Lincoln lubrication systems reduce friction and wear; thereby, decreasing maintenance costs, improving productivity, ensuring a higher level of safety and contribution to the environment.

Our Environmental Management System

Our Environmental Management System according to DIN EN ISO 14001 and EMAS, is an integral part of our company philosophy that reflects Lincoln's future orientation.

Our Motto

Keep in motion –
Bleiben Sie mit uns in Bewegung!

Chain Lubrication



Despite new types of material and advanced technology, many chains still require lubrication. Optimum lubrication reduces friction and subsequent wear on chains. The largest relative movement of all chains occurs between the link plate and the chain stud, and it is here where considerable forces are present. Insufficient lubrication of this area will result in premature wear and chain failure. The consequence is expensive production downtime. Precise and efficient lubrication is a prerequisite for trouble-free operation and a long life of the chain.

Lincoln automated chain lubrication systems provide an exact metered quantity of lubricant and apply it reliably to the chain where it is required.

Advantages of Automated Chain Lubrication

- Increase life expectancy of the chain
- Minimize downtime resulting from insufficient lubrication
- Reduce energy consumption
- Reduce lubricant consumption
- Absorb shocks & beats
- Cooling of fast-running chains

Silencing of noise Suitable Chain Lubricants

All renowned chain manufacturers recommend the periodic relubrication of the chain with a suitable chain lubricant.

The most important chain lubricant requirements are:

- Good penetration characteristics
- High pressure resistance
- Reliable corrosion protection

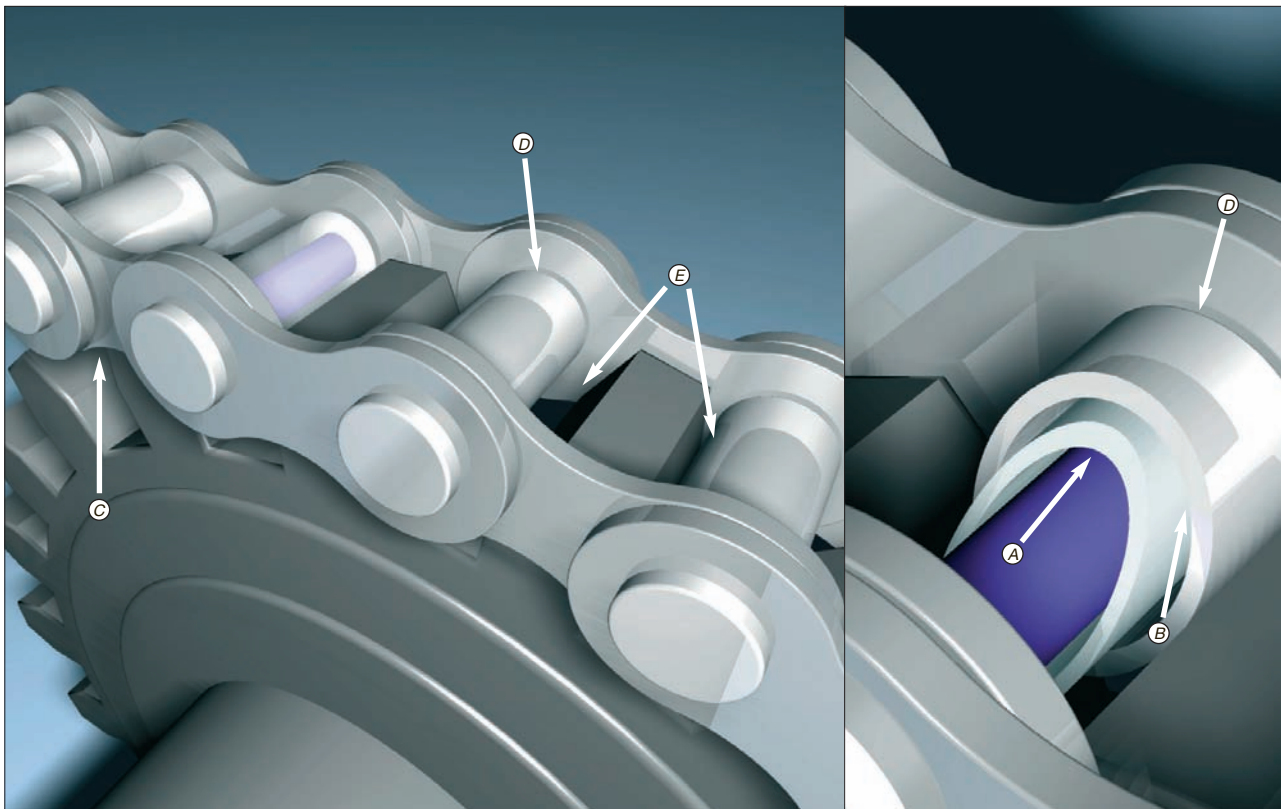

Friction points of a chain:

- Ⓐ Friction between bushing/stud
- Ⓑ Friction between bushing/roller
- Ⓒ Friction between inner/outer plate
- Ⓓ Friction between plate/bushing
- Ⓔ Sprocket/roller/inner plate

Further friction points are found at the drive and chain attachments.

EOS

5

Single-line oil system –
for few, slow moving chains

- Also suitable for mobile equipment
- Brush lubrication



Quicklub

6

Progressive system –
for slow moving, small chains

- Also suitable for mobile equipment
- For grease & oil
- Brush lubrication



Contact Lubrication

7

For conveyor chains in rough
environments

- Cleans, guides and lubricates
in one sweep
- For grease & oil



Centro-Matic

8

Centralized lubrication system –
for chains and chain groups of
machines

- Oil lubrication for slow moving chains
- Squirt and brush lubrication



PMA 2 Solenoid Pump

9

Contact-free oil lubrication –
for fast moving chains

- Intermittent, with squirt nozzles
- Squirt application without air
(airless), non-mist



ORSCO

10

Minimal quantity oil spray system –
for extremely fast moving chains

- Oil lubrication for critical industrial
applications
- Oil and spray air mixture
- Specialty nozzles



COBRA 1X

11

Lubricates the inner rollers and studs
of heavy-duty conveyor chains

- For grease & oil



For inquiries

For the proper selection of a lubrication system we require the following information:

1. Chain size (chain division, total length, number of strands)
2. Chain speed
3. Type of lubricant and required quantity

COBRA 1X chain lubricators are individually designed for each chain. There is a separate questionnaire for this system. If required, please request the form at Lincoln@lincolnindustrial.de

Single-line Oil System for the Lubrication of Slow Moving Chains

EOS is the reliable and most economical solution for the oil lubrication of chains. The system is a direct operating, electrically driven, single-line centralized lubrication system. The system is ideal for machines with chain drives and 12/24 VDC power supply – e.g. agricultural equipment such as balers. A typical industrial application is for packaging machines such as palletizers.



EOS Controller

For machines without a controller, for example balers in the agricultural industry, Lincoln offers a 12/24 VDC controller. The run time is fixed at 4 seconds and the pause time is adjustable from 1 to 100 minutes. The controller enables a simple retrofit installment of the EOS oil lubrication system.

It's different from systems that use basic restrictor or metering elements because the EOS uses a direct operating metering element that offers greater reliability and accuracy. The metering elements supply the re-

particles is minimized. The required metered quantity of oil can be adjusted to properly match the working condition, the size and

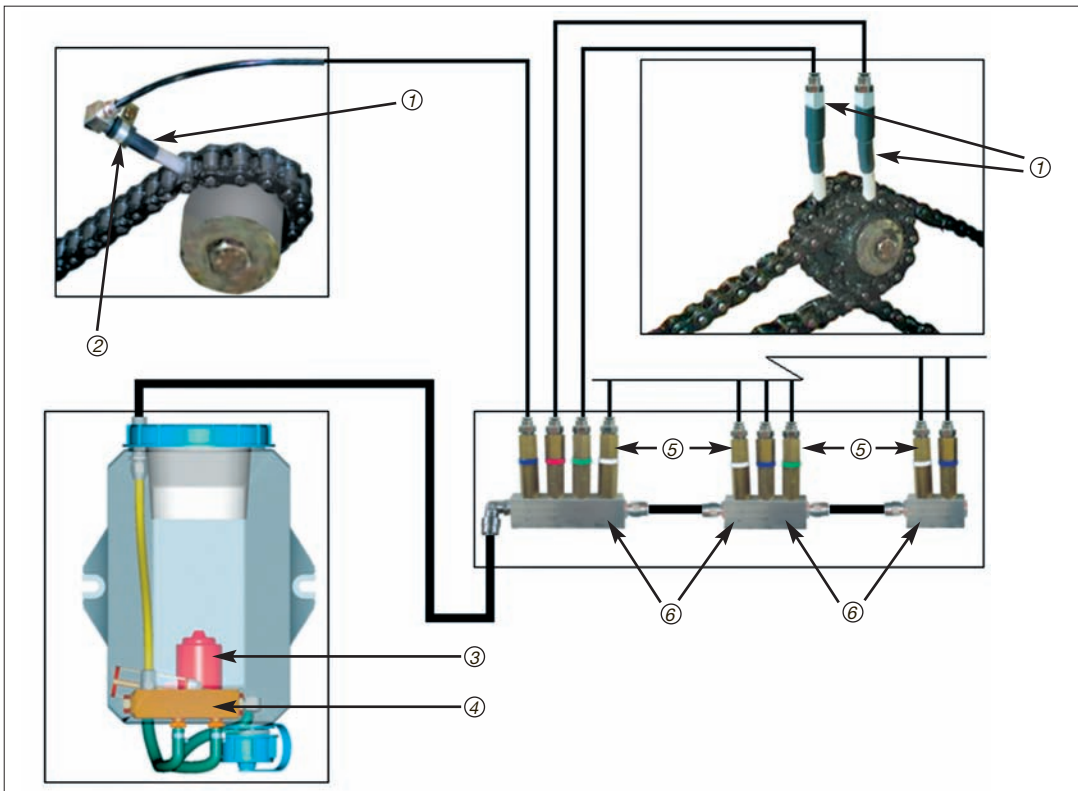

- ① Brush
- ② Bracket
- ③ Electric Motor
- ④ Pressure Unit
- ⑤ Metering Elements
- ⑥ Manifolds for Metering Elements

quired oil quantity in time-controlled intervals to brushes which evenly apply the oil to the chain. Each stroke of the pump charges the metering elements with a predetermined amount of oil and simultaneously supplies the previously charged oil quantity to the brushes. Thereby, all lubrication points receive the exact required, metered quantity of oil. As a result, wear caused by dust or dirt

length of the chain. The frequency of the lubrication interval is determined by the degree of contamination potential that the chain is subjected to. The metering range selection of 0.1, 0.3, 0.4 or 0.5 cm³ provides versatility to ensure that requirements are met.

System Advantages

- Precise, metered quantities of oil reduces wear on the chain and drive
- Metered quantities can be selected to match the chain size and length as well as erating parameters
- 5 litre reservoir provides extended filling intervals
- Push-in fittings provide quick & easy installation
- High supply volume in short time (circa 400 ml/min at 3 bar back-pressure)

Quicklub

Progressive System for Grease or Oil –
for Slow Moving, Small Chains

The Lincoln brush lubrication in conjunction with the Quicklub 203 pump provides an economical entry-level chain lubrication system. The Quicklub range does however offer numerous add-on possibilities. As a result, it fulfils all expectations for an easy, maintenance-friendly and high quality lubrication system.

Brush lubrication not only lubricates the contact points of the links, but rather the entire chain. The pump supplies the lubricant either directly or via a progressive metering device to the brushes, which evenly apply the lubricant to the chain. As a result, high-viscous chain oils and lubricants up to NLGI class 2 can be easily, economically and reliably applied.

A progressive system can serve up to 100 lubrication points, thus several brushes may be positioned along the chains to ensure sufficient lubricant supply.

Optional system monitoring is offered with a 203 pump incorporating the appropriate PCB and corresponding progressive metering devices. Additional options include low level monitoring.

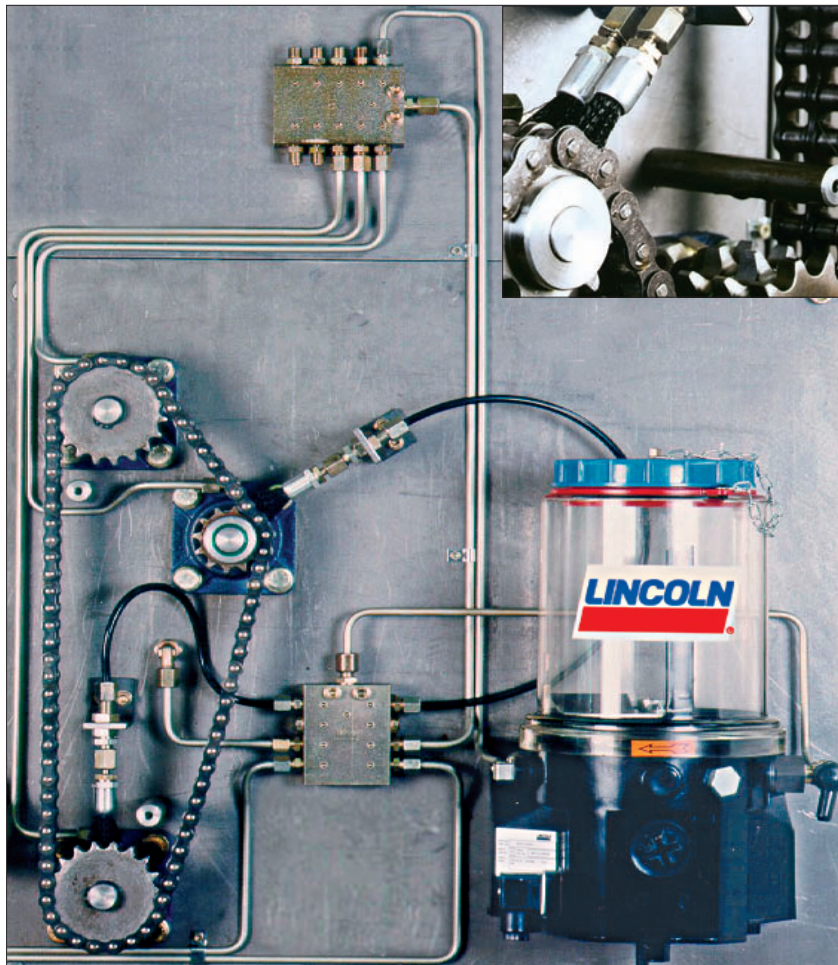

Contact Lubrication

For Conveyor Chains in Rough Environments

The main applications for this genuine simple new lubrication system are transport/conveyor chains found in all industries. This system simultaneously cleans, guides and continuously lubricates the chain – and it has an extraordinary long life thanks to highly wear-resistant plastics that are very robust and insensitive to contamination and knocks.

The system is patent pending and underlies protection of registered design No. 20210758.2.

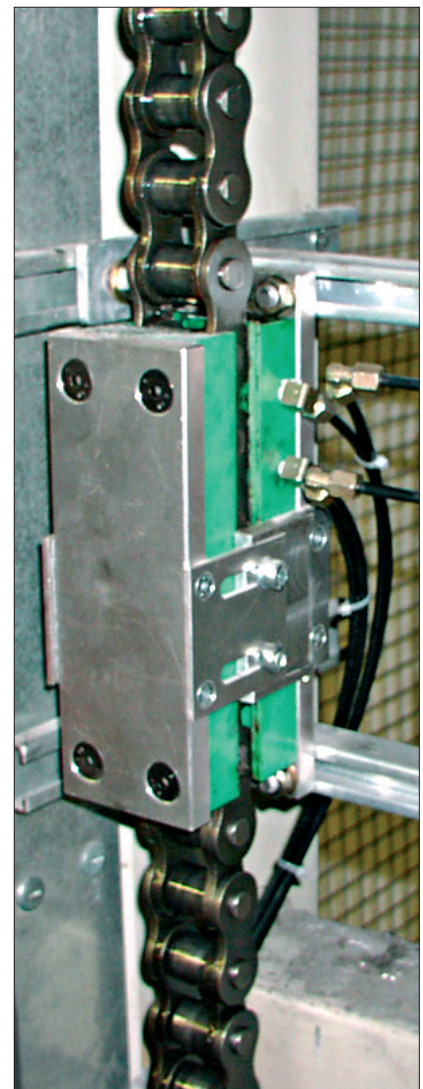

Application Areas

The system has been designed especially for chains in pallet conveyor systems, e.g. in the food and beverage industry. Pallet systems for return goods are particularly exposed to a high grade of contamination: wood chips, broken glass, and in the winter, ice particles stick to the chain and result in premature wear. Other applications for a contact lubrication system are passenger or freight elevators as well as escalators.

For the lubrication of conveyor chains, the newly developed contact lubrication offers essential advantages compared to the conventional brush lubrication. By using a plastic chain guide, the worst of the dirt on the chain is cleaned off and, at the

same time, the chain wear is reduced by an automatic and continuous lubricant supply. Additionally, the chain is held in position or directed by the guide block of the lubrication system.

The Lincoln contact lubrication has an extraordinary long life thanks to highly wear-resistant plastics and is very robust and insensitive to contamination and knocks.

System Characteristics and Advantages

- Cleaning effect of the chain sticking dirt particles are cleaned off
- Suitable for a wide range of roller chains according to DIN 8187 (1/4" single up to 2" double)
- All types of chain lubricants (from low-viscous oil to lubricating grease) can be applied

- Suitable for low and high chain speeds (up to max. 40 m/min)
- Robust and insensitive to contamination and knocks
- Long life due to highly wear-resistant plastics
- Can be supplied with lubricant by any Lincoln centralized lubrication system (progressive system, single-line system, etc.)
- Chain is additionally guided
- Simple and favorable in price

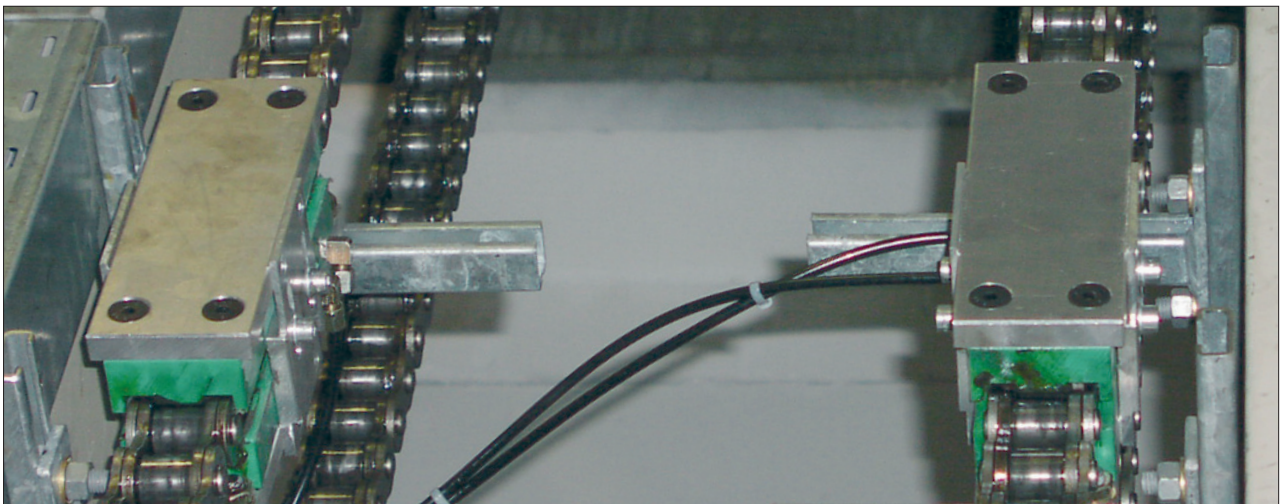

Supply to the guide blocks with a progressive system

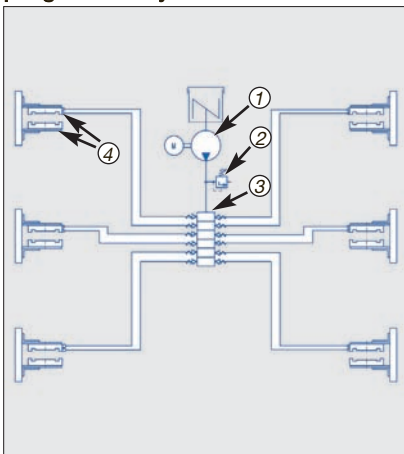

- ① Pump model 203
- ② Over-pressure valve
- ③ SSV 12 progressive metering device
- ④ Guide blocks

Components of Contact Lubrication

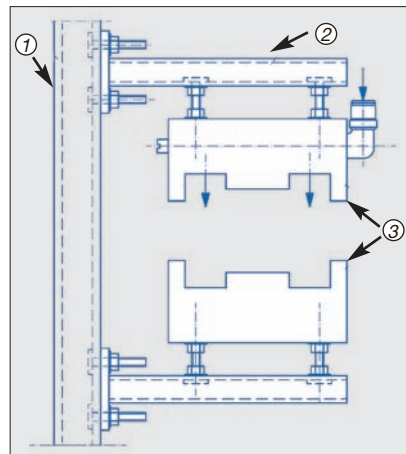

- ① Mounting rail
- ② Console
- ③ Chain guide blocks for single-roller chains

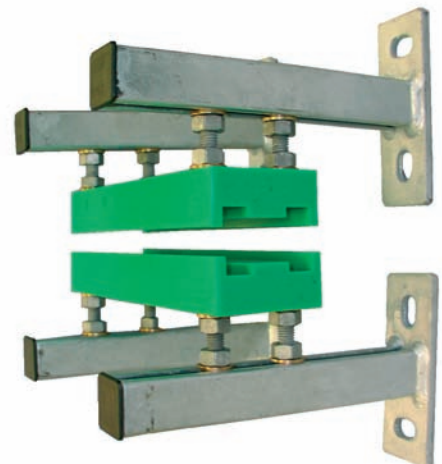

Centro-Matic

Centralized Lubrication System – for Chains and Chain Groups of Machines

The Centro-Matic system is designed for the centralized oil lubrication of slow moving chains and especially for groups of chains that are individually operated.

The chain speed can be up to 6 m/min if brushes are used. For contact-free squirt applications, the chain speed is dependent on the chain division and the number of employed SL-43 lubricant injectors.

Centro-Matic systems meter the oil in exact quantities, independent of the oil viscosity and flow resistance. The oil quantity is adjustable on the SL-43 injector. The high operating pressure of the injector enables an accurate expulsion of oil. The result is optimum chain lubrication and an economical usage of lubricant.

The lubrication of the chain does not require compressed air, the only air that may be required is to drive the pump that supplies the lubricant injectors with oil.

The Centro-Matic oil system operates intermittently with a change in pressure and pressure relief. A centralized pump supplies the connected SL-43 injectors with oil. The injector supplies the metered quantity of oil under pressure (52–69 bar) and the metering chamber is filled. After the mainline pressure has been relieved, the preset quantity of oil from the metering piston is forced in front of the supply piston. SL-43 injectors are infinitely adjustable from 0.016 – 0.131 cm³ and they are equipped with an indicator pin for visual monitoring.

Please inquire about our range of pumps and system controllers.

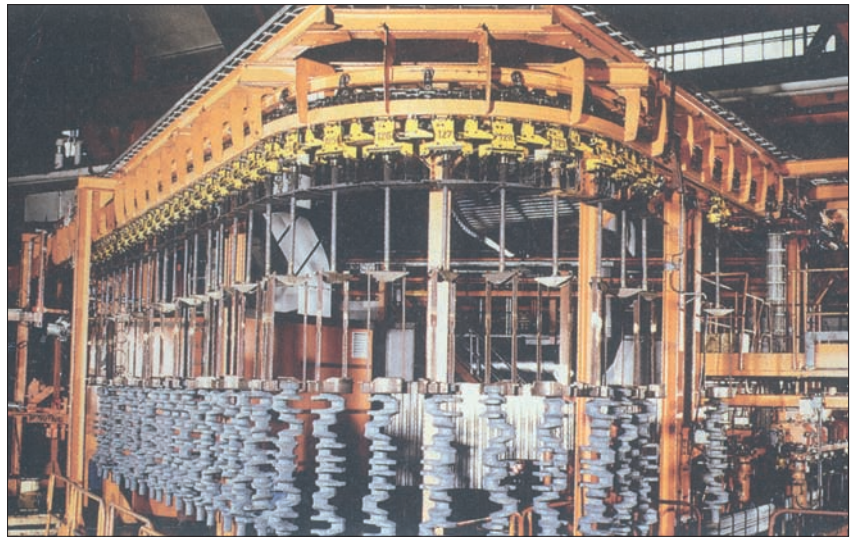

System Advantages

- Switching on and off of individual chain groups is possible
- Exact metering, independent of oil viscosity and flow resistance
- The high operating pressure of the injector enables accurate oil expulsion
- Lubricates without compressed air

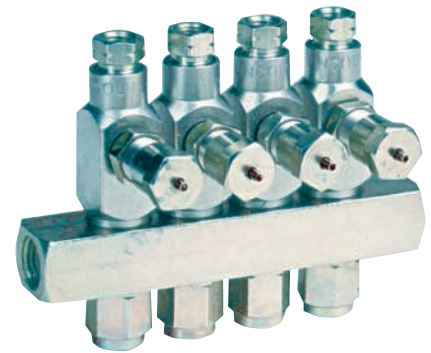

Lubricant injector manifold type SL-43

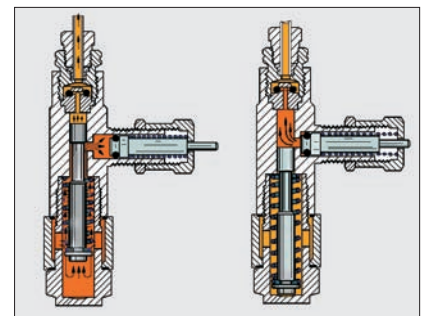

Pressurized

Relieved (vented)

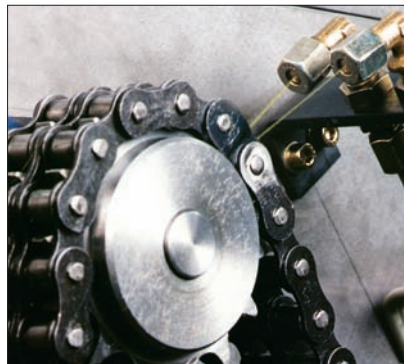

Contact-free oil application via nozzles

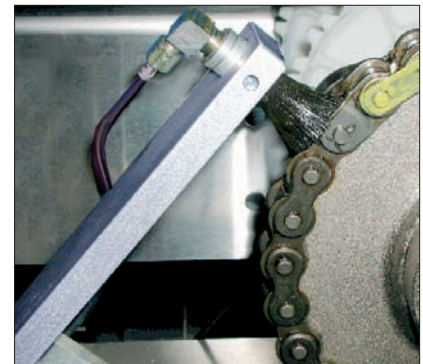

Conventional application via brushes

PMA 2

Contact-free Oil Lubrication – for Fast Moving Chains



The PMA 2 solenoid pump is designed for a contact-free oil lubrication of chains. The exact metered quantity of oil is squir-ted without air (airless), and without producing an oil mist, while the chain is in operation.

The pump is capable of trouble-free lubrication of fast moving chains – maximum 5 cycles per second. A single pump can supply 1 to 6 oil squirt nozzles. The metered quantity of oil per cycle is either 30 mm³ or 60 mm³. Double-nozzles are also available which further increase the number of points served by the pump.

The drive magnet is characterized by its high performance and long duty-cycle, thus enabling a reliable operation of the pump in extreme conditions.

The pump is available in 24 VDC, 120 VAC and 230 VAC versions.



An optional proximity switch for the pump offers a simple method to electrically monitor the function. Other accessories include a 13 or a 36 litre reservoir for oil. Both reservoirs are equipped with electrical low-level control and a large filling port comprising a strainer.

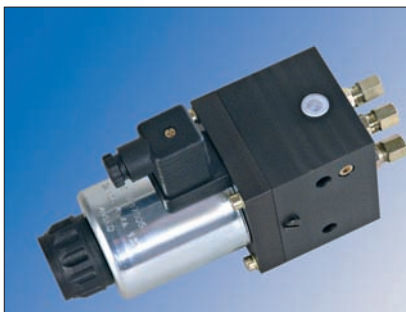
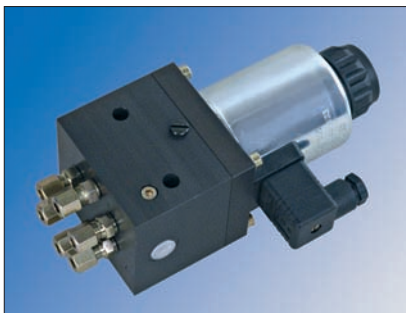

System Advantages and Features

- Metered oil quantity 30 mm³ or 60 mm³ per cycle
- Available in 24 VDC, 120 VAC and 230 VAC versions
- Optional electrical monitoring via a proximity switch
- 1 to 6 outlets that can serve individual or double nozzles
- Up to 5 lubrication cycles per second (depending on the system)
- Airless lubrication – oil mist free

ORSCO

Minimal Quantity Oil Spray System – for Extreme Fast Moving Chains

The ORSCO spray system covers the entire oil lubrication range from slow to fast moving chains. It is, however, especially ideal for the lubrication of extreme fast moving chains or for critical applications such as found in the food & beverage industry, or for integrate assembly procedures.

The ORSCO spray system operates exceptionally effectively and economically because it uses a pneumatically operated injector that is capable of supplying minute quantities of oil – for example – a drop (0.015 cm³) per stroke.

Each spray nozzle is supplied by an injector pump that operates intermittently, and which is cycled by a controller. The cycle time is dependent on the lubricant requirement of the chain. The system operates on a minimum cycle time starting at 0.5 seconds. In the operating cycle, oil and compressed air are only first mixed within the spray nozzle body (see illustration). The oil and spray air are combined in the mixing chamber. The spray air transports the lubricant film to the nozzle opening (1.2 mm). Depending on the quantity and viscosity of the oil, a minimum air pressure of 0.4 bar is sufficient to produce a fine jet of oil spray.



Series VSR Pump model

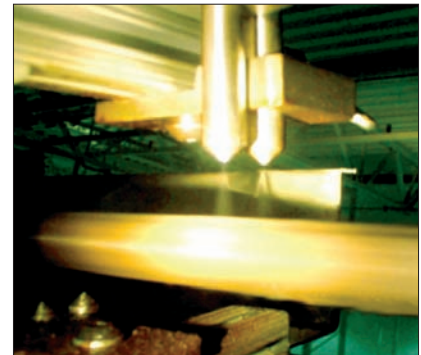

High-speed chain

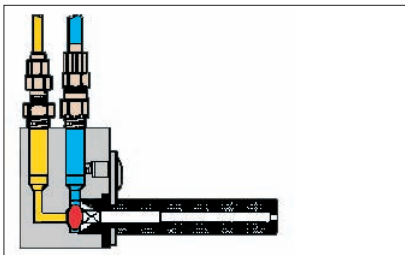

● Oil ● Air

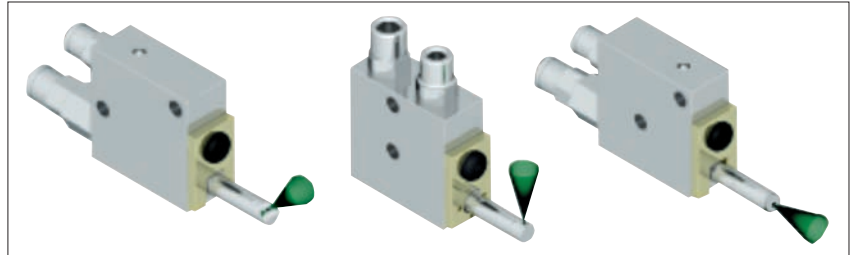

Spray Nozzle Types

The system combines oil and spray air in a special mixing chamber. The compressed air acts merely as a transport medium to carry the minute oil quantity to the point of lubrication (not an oil-mist lubrication).

When the injector pump is fired in longer intervals, a thin oil film develops on the inside wall of the mixing chamber. The result is a fine spray stream. If the injector is fired in shorter intervals, a thicker oil film builds up on the wall of the mixing chamber, and the result is an increased saturated oil spray stream. The compact series VSR pump model (see picture) can be equipped with up to 8 injector pumps.

Please inquire for systems with more nozzles, or for controllers and monitoring functions.

System Advantages and Features

- Extremely precise minimum quantity spray lubrication
- Nozzles are available with different spray patterns

COBRA 1X



Lubricates the Inner Rollers & Studs of Heavy-duty Chains with Grease or Oil

The enhanced COBRA 1X from Lincoln's chain lubrication range is particularly suitable for conveyor chains and conveyor lines, in which the inner roller and stud of the chain are lubricated while the chain is in operation. The system can supply either NLGI class 2 grease or oil.

A new drive technology, which is a combination of a pneumatic and mechanical drive, as well as a newly designed lubrication head, provides two key advantages:

- The load subjected to the chain is substantially lower
- A higher maximum lubricant pressure of up to 150 bar is possible

The newly designed lubrication head enables an exact metering from 0.2 cm³ to 2 cm³ per lubrication cycle, and the adjusting screw permits infinite metering adjusting within this range.

Visual monitoring of the lubrication head function is performed via the movement of an indicator pin.

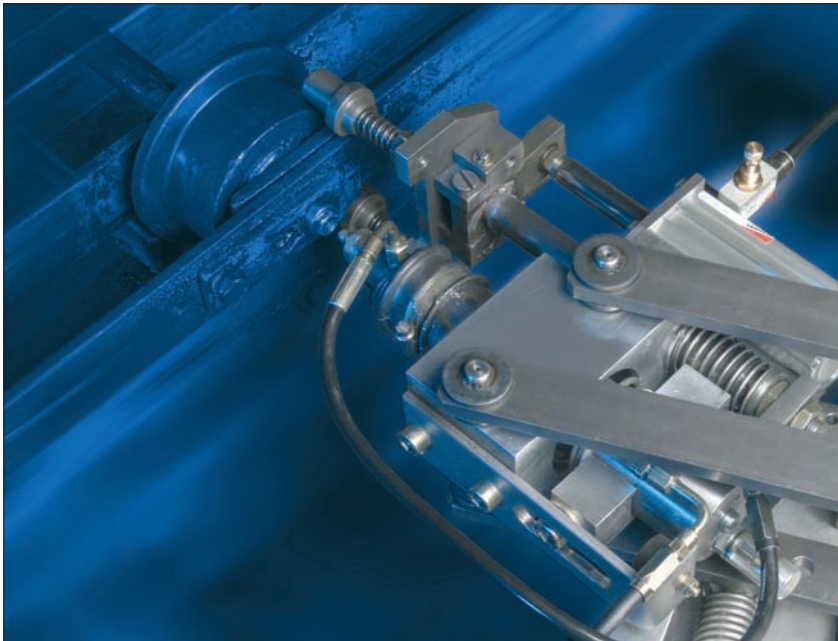
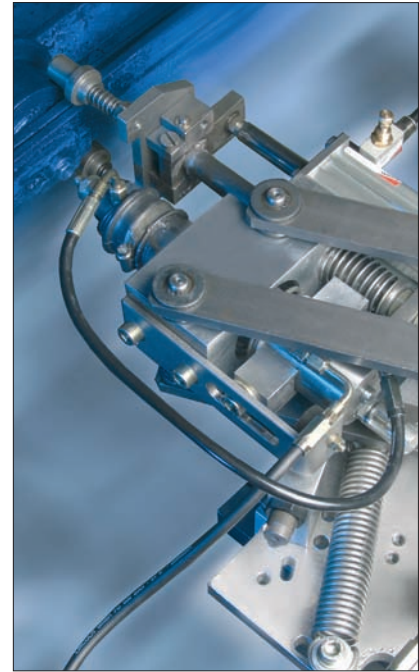
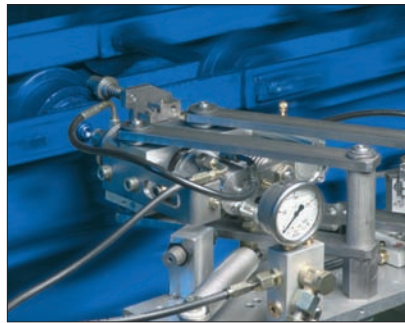

System Benefits

- For oil and grease up to NLGI class 2
- Lubrication frequency of 1 cycle per second
- Supply quantity of 0.2 cm³ to 2 cm³ per stroke
- Lubricant pressure of max. 150 bar
- For chain speeds up to 20 m/min
- Manual Start/Stop or optional automated (electro pneumatic)
- Visual monitoring via indicator pin
- No control cabinet required (for the standard version)

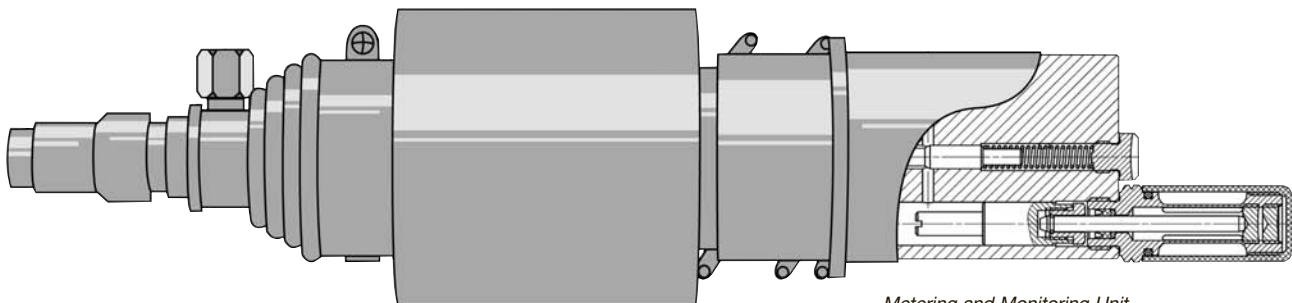

Metering and Monitoring Unit

Lincoln's Global Distribution and Service Network

The Best in our Industry

Hundreds of Lincoln System Houses are available for you – worldwide

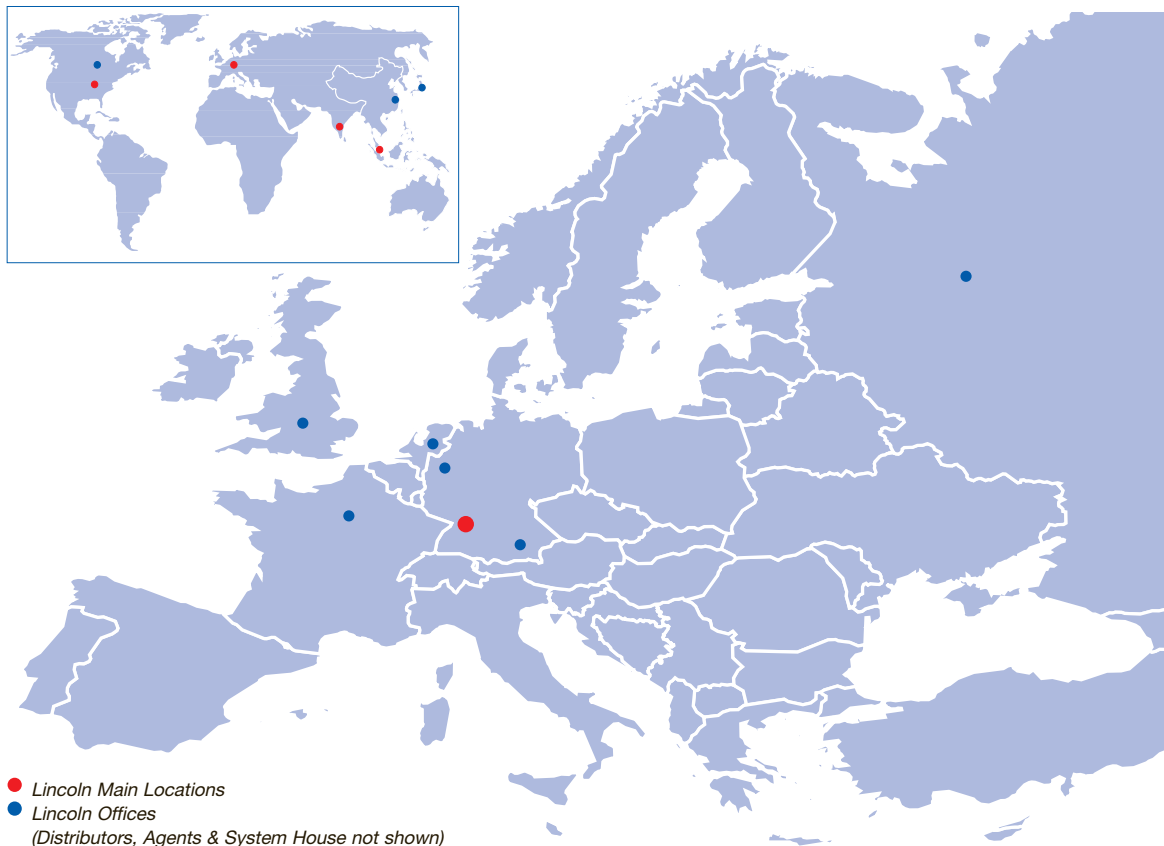

In all levels of service – lubrication system selection & evaluation, custom-engineered system installation, or the supply of top-quality products – the employees of our Lincoln locations, offices, agents and distributors make certain you always get the very best value.

System House Distributors

Our system house distributors offer the highest level of expertise available in the industry. They custom-design systems with the exact combination of Lincoln components you need.

Then they install the system at your facility with experienced technicians or work with your personnel to ensure the job is done correctly. Each distributor stocks a full inventory of pumps, metering devices, controllers and accessories. Each continues to meet our stringent requirements for product, systems and service knowledge. From St. Louis to Singapore, Walldorf and worldwide, Lincoln's top-of-the-industry system house distributors will be there when and where you require them.

For the nearest authorized Lincoln sales and service representative, contact:

Americas:

St. Louis, Missouri
Phone +1 314.679.4200
Fax +1 800.424.5359
www.lincolnindustrial.com
Where to buy

Europe/Middle East/Africa:

Walldorf, Germany
Phone + 49.6227.33.0
Fax + 49.6227.33.259
www.lincolnindustrial.de
CONTACT

Asia/Pacific:

Singapore
Phone + 65.65880188
Fax + 65.65883488



Lincoln GmbH
Heinrich-Hertz-Str. 2-8
D-69190 Walldorf · Germany
Tel. + 49.6227.33.0
Fax + 49.6227.33.259

lincoln@lincolnindustrial.de
www.lincolnindustrial.de
© Copyright 2009
Printed in Germany
Form W-128-En-0609

DIN EN ISO 9001
durch DQS
Reg.-Nr. 799

DIN EN ISO 14001
durch GUT