

**KOMATSU**

# **GD825A-2**

**MOTOR GRADER**



Pictures may contain equipment not available in some areas.

Flywheel Horsepower 209 kW **(280 HP)**

Blade Length 4878 mm **(16')**

Operating Weight 26350 kg **(58,090 lb)**

**KOMATSU**

# KOMATSU SETS THE STANDARDS IN...

## PERFORMANCE

**Large drawbar pull:** The S6D140E engine features a dynamic power output of 209 kW (280HP) and a tenacious torque. Combined with the large operating weight, the GD825A-2 produces a massive drawbar pull making it the ideal machine for heavy-duty haul road maintenance jobs. The direct injection system contributes to low fuel consumption for efficient operation.

**Clean engine:** The S6D140E engine is designed to reduce emissions and to meet the regulations of the U.S.A. which is the severest regulation in the world.

**High travel speed:** The HYDROSHIFT transmission spreads the massive power of the engine over a super wide range of 8 forward and 8 reverse speeds. This allows the operator to select the optimum travel speed for efficient haul road grading or cleanup work.

**Stable travel with wide-base tires:** The standard tires on GD825A-2 are 23.5-25-12PR (L3) wide-base tires, which feature a big width and low ground pressure. Since the wide-base tires do not sink very much in soft ground, they are good for driving through soft ground without getting stuck. On jobsites where there is a lot of sharp rocks or nails, the wider tires are that much more likely to run over such obstacles.

**High stability:** Weight distribution on the front and rear wheels is well balanced, particularly the large weight on the front wheels leads to less side slip and greater productivity under heavy-duty conditions. The GD825A-2 features a large blade force to easily penetrate the ground on tough haul roads, ensuring efficient grading operation with fewer passes.



**High blade performance:** The operator can position the blade at the desired bank cutting angle up to 90 degrees on either side, without leaving the operator's compartment. The high blade rotating speed facilitates quick blade changes for increased productivity. A large shoulder reach and hydraulic blade tip control allow the operator to match the GD825A-2 to the most demanding applications.

**Articulated frame:** A 25 degrees frame articulation gives the GD825A a minimum turning radius of 7.9 m (25'11"), making it easy to maneuver in tight quarters. Three basic operating postures are available to meet your varying needs: Straight frame suitable for long-pass grading, articulated frame for tight turning and offset frame for locating drive wheels on prepared ground.

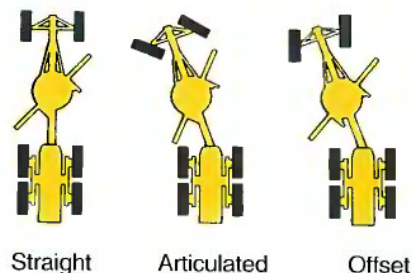
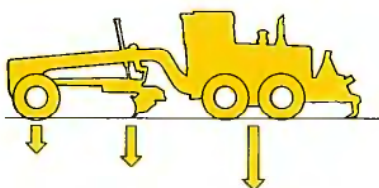

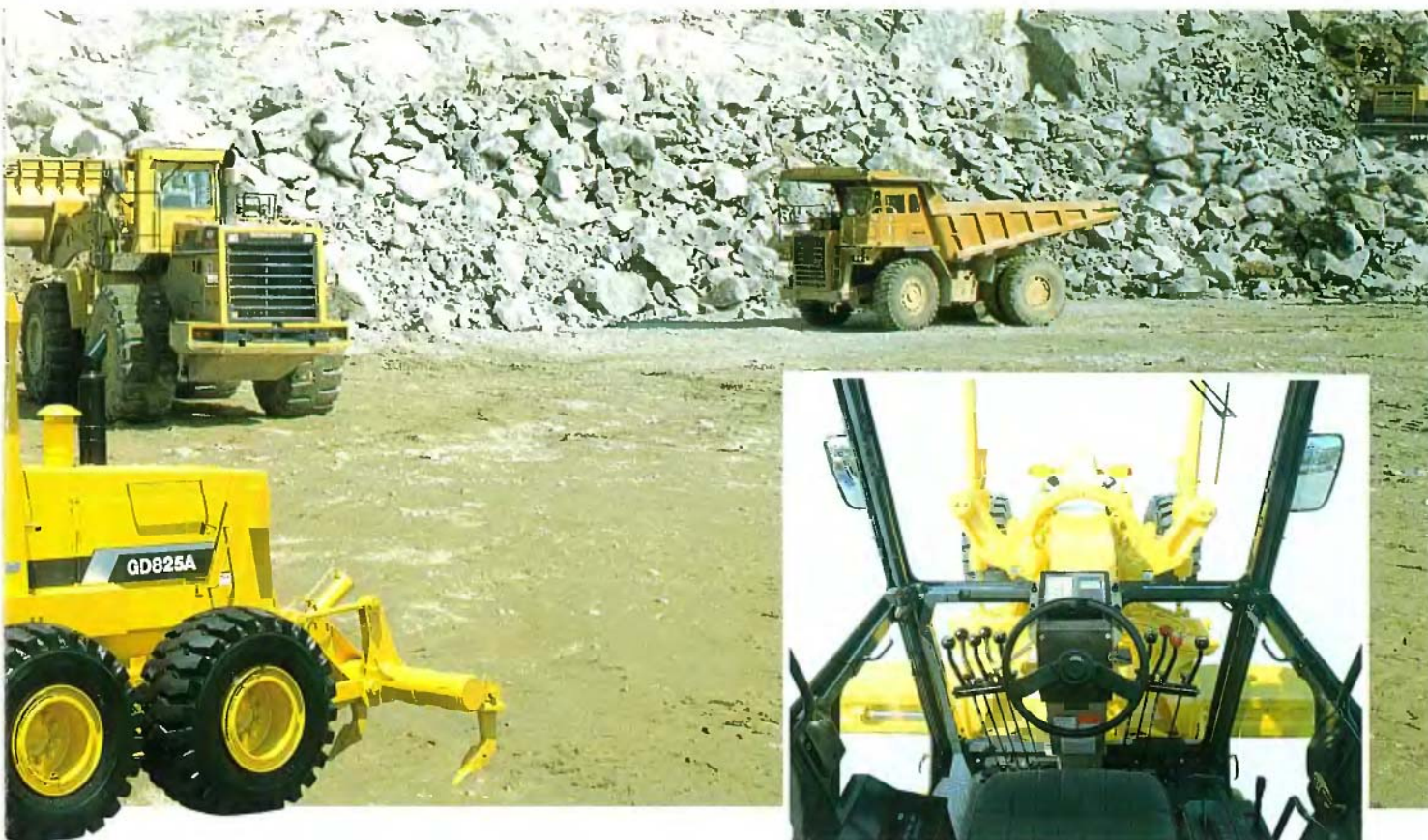

## EASY OPERATION

**CLSS:** The CLSS (Closed-center Load Sensing System) offers precise and responsive implement control by supplying the required amount of oil to the hydraulic cylinders. Pressure compensation valve provides excellent simultaneous operation ability. The variable capacity pump discharges only the required amount of oil, which means fuel consumption and operating noise are reduced.

**Rear frame-mounted operator's compartment:** This ergonomic design enables the operator to watch

the blade control easily. In addition, the operator's compartment faces the traveling direction even during offset operation, giving the operator a natural feeling.

**Comfortable operator's environment:** Suspension seat with armrest is adjustable in three different positions. In addition, work equipment levers, steering wheel and console are tiltable, giving the perfect operating position. Noise and vibration are reduced, because of rubber-mounted compartment and because the con-

trol valves are mounted isolated from the floor. The cab with large glass and ample interior space improves operator comfort and visibility.

**Inching and decelerator pedals:** Hand throttle plus foot throttle/heel decelerator and inching pedal allow the operator complete control of ground speed.

**Engine key stop system:** To stop the engine, simply turn off the ignition key.

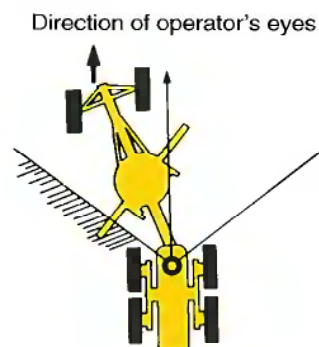
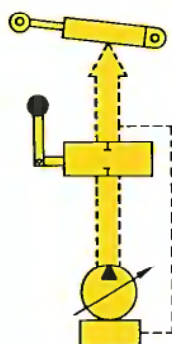
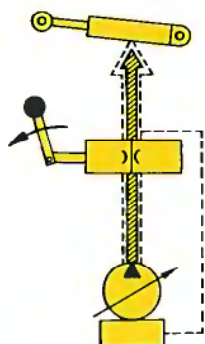

## HIGH RELIABILITY/ DURABILITY

**Double-walled gooseneck:** The GD825A front frame uses a box-structure design, constructed of thick plates, providing the durability required for heavy duty haul road maintenance. In addition the side plates of the gooseneck, where loads and shocks are most concentrated, are double walled constructed to eliminate cracking, for reliable long life frame.



**Circle drive slip clutch** – protects circle shoes and teeth from damage. Should a large rotational force be placed against the blade (as when striking a buried rock) the clutch will slip and the impact load placed against frame will also be absorbed.

**Heavy-duty differential:** Taper roller bearings support the large pinion gears and cross joint for large load capabilities. Pressure lubrication prevents heat build up, increasing durability.

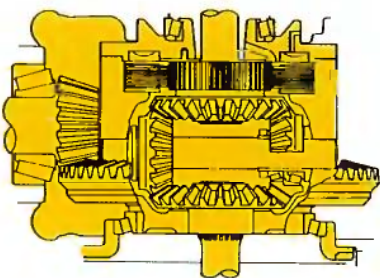

**Electrically controlled transmission featuring contactless switches:** The electrically controlled transmission ensures smooth, light touch speed and directional changes. Contactless switches are utilized to eliminate any mechanical wear or corrosion thus increasing reliability and reducing maintenance.

**Wet, multiple-disc brakes:** Located on all tandem wheels are oil cooled and adjustment free multi disc brakes. Dirt and other contaminants are sealed out, thus ensuring longer service life. Sure braking performance is maintained even when operating on muddy terrain.

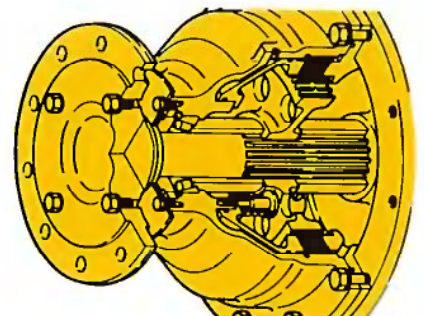



## MINIMUM MAINTENANCE

**Electronic display and monitoring system,** installed on the steering post in easy view of the operator is the display/warning system which continuously monitors all operating systems. If a malfunction should occur, the operator is immediately warned which system is experiencing trouble. This prevents minor problems from becoming major ones.

**Six circle guide shoes for optimum blade operation:** Guide shoes ensure precise blade operation, low shoe wear, smooth blade rotation and increased torque.

**Elevating cab:** Elevating the cab facilitates quick and easy maintenance of the hydraulic piping and control linkage under the cab. The cab can be raised 710 mm (2'4") on the job site without disconnecting any hydraulic piping and linkage.

**Simplified components layout:** Major hydraulic components are logically located to be easily accessible from the ground. All major hydraulic valves and filters are located outside the main frame for easy access. High positioned hydraulic reservoir prevents pump cavitation and eliminates bleeding air from the lines after oil or filter replacement reducing maintenance time.



**Note:** Before using elevating mechanism, ask Komatsu distributor for instructions on the safe and proper way to lift cab.

# GD825A-2 SPECIFICATIONS



## ENGINE

Komatsu S6D140E, 4-cycle, water-cooled, overhead-valve, turbocharged diesel engine of 6 cylinders with 140 mm (5.51") bore x 165 mm (6.50") stroke and 15.24 ltr. (930 in<sup>3</sup>) piston displacement.

Flywheel horsepower:

280 HP (209 kW) @ 2100 RPM (SAE J1349)

284 PS (209 kW) @ 2100 RPM (DIN 6270 NET)

Direct-injection for fuel economy. Mechanical all-speed governor. Gear pump-driven forced lubrication with full-flow filter. Dry-type air cleaner with automatic dust ejector, precleaner and dust indicator for extended element service intervals. 24 V/11 kW electrical starting system. 24 V/50 A alternator. 2 x 12 V/200 Ah batteries.



## HYDROSHIFT TRANSMISSION

The Komatsu HYDROSHIFT transmission consists of planetary gears and hydraulically actuated and force-lubricated multiple-disc clutches, assuring light-touch, effort-minimizing shifting. Both speed shifting and direction changes are completed by a single lever. With the inching pedal, precise finishing operation and smooth machine starts are ensured. A super wide range of 8 forward and 8 reverse speeds match all job requirements. Accidental machine starts are prevented by a gearshift lock device and engine starts only when the shift lever is set in the parking position.

### Travel speeds (at rated engine RPM)

	1st	2nd	3rd	4th	5th	6th	7th	8th
Forward								
km/h	4.0	5.4	8.0	11.5	15.8	21.4	31.3	44.9
(MPH)	(2.5)	(3.4)	(5.0)	(7.1)	(9.8)	(13.3)	(19.5)	(27.9)
Reverse								
km/h	4.3	5.8	8.5	12.2	16.9	22.8	33.4	47.9
(MPH)	(2.7)	(3.6)	(5.3)	(7.6)	(10.5)	(14.2)	(20.8)	(29.8)
Max. drawbar pull	14705 kg (32,420 lb)							



## FINAL DRIVE

Double-reduction final drives of spiral bevel gear with electric-over, hydraulically controlled differential lock/unlock device and planetary gear. Roller-chain tandem drives for four rear wheels. Tandem case pivots up to 15°, assuring high machine stability and positive traction during operation.



## AXLES

**Front axle:** Reverse Elliot-type front axle with a center ground clearance of 680 mm (2'3") and oscillation angle of 32° (total) assures stable machine travel. Hydraulic front wheel leaning (18° to each side).

**Rear axle:** Full-floating rear axle is made of forged heat-treated steel.



## WHEELS

Front and rear tires ..... 23.5-25-12 PR (L3) rock-type tires  
Rims ..... 19.50 x 25 WTB  
Inflation pressure ..... 2.6 kg/cm<sup>2</sup> (37 PSI)



## STEERING

Full-hydraulic orbit-roll type steering control system with two steering cylinders are directly actuated on the knuckle arm. Maximum steering angle of front wheels is 50° left and right.

Frame articulation angle ..... 25° left and right  
Min. turning radius (frame articulated) ..... 7.9 m (25'11")



## BRAKES

**Service brakes:** Foot-operated, wet, multiple disc brakes are air-actuated on 4 rear wheels and sealed for adjustment-free operation. Two, crossed brake lines for sure braking.

**Parking brake:** Mechanical, dry, disc type actuated on transmission output shaft. Spring-applied and air-released.



## FRAMES

Frames are articulated by two hydraulic cylinders. Box-sectioned front and rear frames are steel-plate-welded constructed and connected with an articulation pin. One-piece-frame design for the front frame in which hydraulic pipings are installed offers excellent front visibility for more precise operations.

Front frame section (width x height)

..... 350 mm x 400 mm (1'2" x 1'4")



## BLADE EQUIPMENT

**Drawbar:** A-shaped, U-section press-formed and welded construction for maximum strength.

**Circle:** Hydraulically controlled, internal gear type circle with six guide shoes for smooth 360° rotation.

Circle diameter (outer) ..... 1775 mm (5'10")

**Moldboard:** Box-section constructed with wear-resistant steel. Hydraulic blade sideshift and tip control. Side edges are attached.

Length x height x thickness

..... 4878 mm x 850 mm x 25 mm (16' x 2'9" x 0.98")

Blade base ..... 3100 mm (10'2")

Blade load ..... 14145 kg (31,180 lb)

**Cutting edges:** Flat type cutting edges meet SAE standard J738

No. of cutting edges ..... 2

Length x height x thickness

..... 2438 mm x 254 mm x 25 mm (8' x 10.0" x 0.98")



## BLADE RANGE

All blade movements and positions can be hydraulically controlled from the operator's seat.

Max. lift above ground ..... 420 mm (1'6")

Max. drop below ground ..... 680 mm (2'3")

Max. shoulder reach:

Left ..... 2400 mm (7'10")

Right ..... 2400 mm (7'10")

Max. bank cutting angle ..... 90°

Hydraulic blade tip ..... 49° forward, 5° backward

Cutting angle ..... 60.5° ~ 118.5°



## HYDRAULIC CONTROL UNIT

**Hydraulic pumps:** One variable-capacity piston pump powers the work equipment and steering system.

Capacity.....278 ltr. (73.4 U.S. gal.)

One gear pump for HYDROSHIFT transmission

Capacity.....133 lt. (35.1 U.S. gal.)

One gear pump for differential

Capacity.....17 lt. (4.5 U.S. gal.)

**Hydraulic motor:** Piston-type hydraulic motor of 66 HP (49 kW) output power is used for blade rotation.

**Hydraulic cylinders:** Double-acting piston type hydraulic cylinders: two for blade lifting, one for drawbar sideshifting, one for blade sideshifting, one for front wheel leaning, one for blade tipping, two for front wheel steering and two for frame articulation. Pilot check valves assure positive cylinder action (excluding a blade sideshift cylinder).

**Control valves:** Two, 5-spool type control valves for work equipment controls. Relief valve built into control valves for sure control.

### Relief valve setting:

Work equipment ..... 250 kg/cm<sup>2</sup> (3,560 PSI)

Steering ..... 195 kg/cm<sup>2</sup> (2,775 PSI)

Transmission ..... 31 kg/cm<sup>2</sup> (440 PSI)



## SERVICE REFILL CAPACITIES

Coolant .....58 ltr. (15.3 U.S. gal.)

Fuel tank.....500 ltr. (132.1 U.S. gal.)

Engine .....38 ltr. (10 U.S. gal.)

Transmission .....25 ltr. (6.6 U.S. gal.)

Tandem case (each side) .....190 ltr. (50.2 U.S. gal.)

Final drive case .....63 ltr. (16.6 U.S. gal.)

Hydraulic oil .....80 ltr. (21.1 U.S. gal.)



## OPERATING WEIGHT (approximate)

Operating weight, including rated capacity of lubricant, coolant, full fuel tank, hydraulic equipment, operator, 4878 mm (16') blade and 23.5-25-12PR (L3) rock-type tires, optional ROPS canopy and steel cab (low-profile type) and the standard equipment.

On front wheels ..... 7970 kg (17,570 lb)

On rear wheels ..... 18380 kg (40,520 lb)

Total weight ..... 26350 kg (58,090 lb)

## STANDARD EQUIPMENT

**ENGINE AND TRANSMISSION:** 280 HP (209 kW) diesel engine. 24 V/11 kW starting motor. 24 V/50 A alternator. 2 x 12 V/200 Ah batteries. Corrosion resistor. Dry-type air cleaner with automatic dust ejector and precleaner. Pusher type fan. Engine side covers. Muffler. Hand throttle. Accelerator, decelerator and inching pedals. HYDROSHIFT transmission. Lock/unlock differential.

**METERS, GAUGES AND MONITORING SYSTEM:** Service meter. Air pressure gauge. Water temperature gauge. Fuel gauge. Dust indicator. Blade bank pin retract indicator. Electronic display monitoring system (for final-drive oil temperature, engine oil pressure, coolant level, coolant temperature, air pressure, alternator charging, engine oil level, hydraulic oil level, engine preheating). Speedometer.

**MOLDBOARD:** Hydraulic blade sideshift and hydraulic blade tip control, 4878 mm (16') blade with two 8 feet cutting edges, circle drive slip clutch.

**BRAKES:** Foot-operated oil-disc brakes for four rear wheels. Hand-operated, dry, disc type parking brake.

**TIRES:** 23.5-25-12PR (L3) rock-type tires (front and rear).

**OTHERS:** Adjustable console and work-equipment control levers. 2-way adjustable seat. Horn. Backup alarm. Head lights. Front working lights. Working lights for blade. Rear working lights. Back-up light. Stop and tail lamps. Panel lamp. Pilot check valves for blade lift, blade tipping, front wheel leaning, drawbar sideshift and frame articulation cylinders. Rear drawbar.



## DIMENSIONS

Low-profile ROPS and steel cab, push-plate and rear-mounted ripper are optionally available.

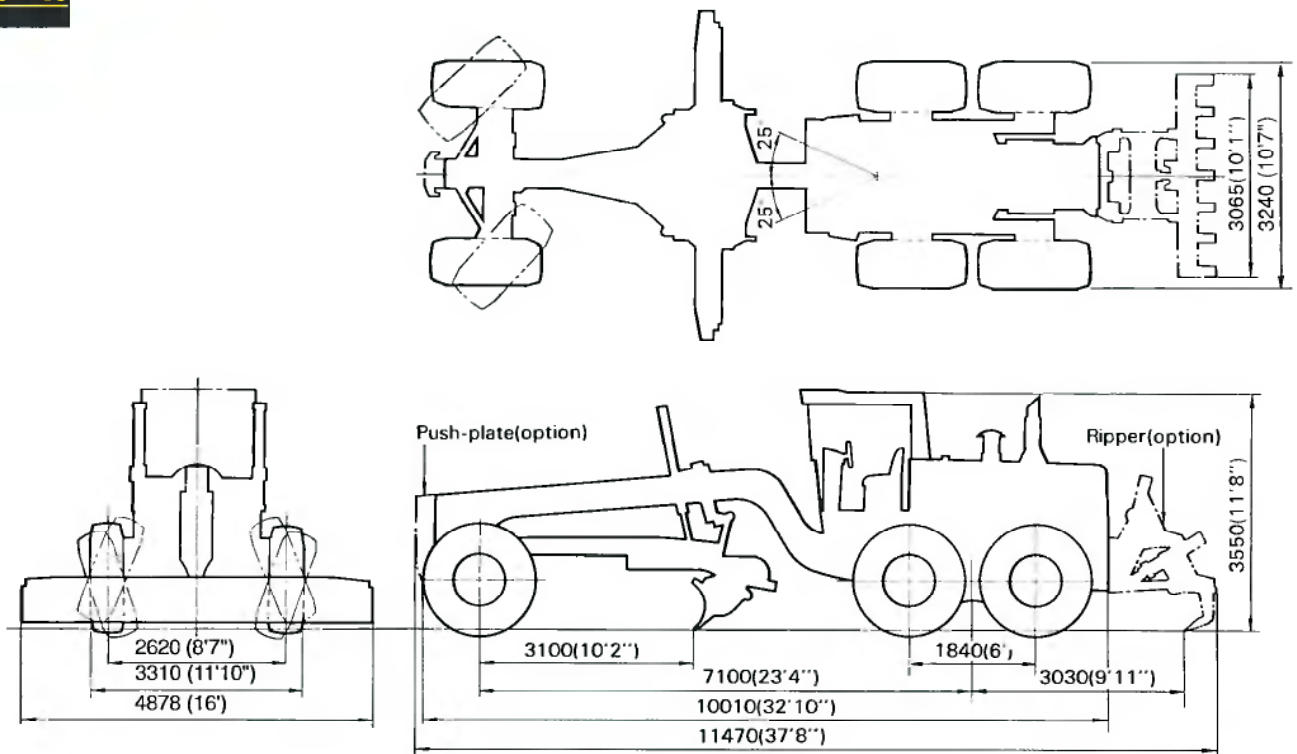

Ground clearance ..... 440 mm (1' 5")

Unit: mm (ft.in)

## ATTACHMENTS AND OPTIONAL EQUIPMENT



**Rear-mounted ripper:** Four, parallel linkage type. With hydraulically controlled raise and lower functions, this ripper can be used to dig out rocks or hard ground not removable by a scarifier.

No. of shanks ..... 3  
 (Max. 7 shanks installable)  
 Max. digging depth ..... 480 mm (1'7")  
 Max. lift above ground ..... 675 mm (2'3")  
 Max. digging width ..... 2980 mm (9'9")  
 Additional weight ..... 2585 kg (5,700 lb)  
 (including front push-plate)



### ROPS cab

Includes ash tray, front window washer and front wipers, seat belt, right and left outside and interior rear view mirrors.

### Low-profile type

Weight ..... 1000 kg (2,205 lb)  
 Installed height ..... 3550 mm (11'8")

### OPTIONAL EQUIPMENT

23.5-25-12PR (L2) tires  
 Air conditioner with heater defroster  
 Heater and defrosters  
 Push plates  
 Blade extension (2')  
 Float position blade control  
 Auxiliary steering  
 Window wiper, door lower  
 Transmission underguard  
 Vandalism protection kit  
 Blade accumulator  
 203 mm x 19 mm (8.0" x 0.75") cutting edges

## MAIN FEATURES

### High reliability and durability

- Double-walled gooseneck and box-structure in front frame and heavy-duty differential assure greater reliability.
- Electrically controlled transmission with contactless switches offers maximum reliability.

### Minimum maintenance

- Electronic display/monitoring system helps prevent minor problems from becoming major ones.
- Elevating cab and simple hydraulic piping provide easy access and maintenance for hydraulic units.

### High maneuverability and easy operation

- High-power S6D140E engine and large operating weight provide large drawbar pull and blade load for efficient operation.
- Well-balanced weight distribution assures minimum sideslip even in heavy-duty condition.
- CLSS (Closed-center Load Sensing System) assures precise and responsive implement control.
- Rear-frame-mounted operator's compartment enables excellent view of the machine's traveling direction.

This specification sheet may contain attachments and optional equipment that are not available in your area. Please consult your local Komatsu distributor for those items you may require. Materials and specifications are subject to change without notice.

**KOMATSU**