



WHEELED LOADING SHOVEL | 432ZX

Operating weight: 12,100kg Gross engine power: 112kw (150hp) Full turn tipping load: 7,618 kg Standard shovel capacity: 2.1m³



DURABILITY AND BUILD QUALITY.

THE JCB 432ZX IS DESIGNED TO WITHSTAND ALL THE HARD WORK YOU CAN THROW AT IT. WE'VE STRESS AND CLIMATE-TESTED IT, AND FITTED ONLY PREMIUM COMPONENTS TO GUARANTEE DURABILITY.

Because industry is tough, we stress test to emulate the toughest digging and dump situations. That means all structures can perform even the most arduous duties over thousands of hours.



Extreme testing, extreme durability.

1 Because JCB 432s are used by customers all over the world, we've tested it rigorously in climates ranging from -20°C to 50°C. Its T2 Cummins engine has excellent filtration and robust fuelling to handle varying fuel quality.

2 By using advanced manufacturing and assembly processes, we produce only the very highest precision quality components.

3 IP69 & IP67 electrics keep out water and dust.

4 The 432ZX is equipped with tried and proven ZF transmission and Graziano axles. The rear counterweight and cast quarter pillars protect the cooling pack and the back end of the machine from damage

5 Our durable centre joint features twin taper roller bearings as well as a heavy-duty pin and bush assembly. To protect steer rams and hoses from damage, they're positioned high up above the robust centre joint.



POWER AND PRODUCTIVITY.

TO MAKE SURE THE 432ZX IS AS PRODUCTIVE AS POSSIBLE, WE'VE FITTED IT WITH A SUPREMELY EFFICIENT, TRIED AND TRUSTED POWERTRAIN AND LOADER ARM.

The 432ZX's Z-type loader arm geometry generates maximum breakout forces and increased reach when lorry loading.



We use a simple and very reliable hydraulic circuit that comprises twin gear pumps and an unloader valve block. The versatile optional three spool valve block means you can use attachments like grabs and sweepers. A standard float function means grading and levelling is simplified.

Where power meets efficiency.

- 1 The 432ZX high lift loader arm gives it the ability to dump into the centre of wagon to help give quick and even loading.
- 2 A ZF fully automatic 4-speed 4WD powershift transmission automatically senses the perfect gear for any application. For increased traction, there's also a manual gear kickdown function on the loader lever.
- 3 The 432ZX has axles with limited slip differentials fitted as standard to provide maximum traction in any ground conditions.



OPERATOR SAFETY AND COMFORT.

TO GET THE MOST FROM YOUR MACHINE, YOU NEED TO GET THE MOST FROM YOUR OPERATOR. THAT'S WHY WE'VE DESIGNED THE 432ZX TO BE A SAFE AND COMFORTABLE PLACE TO WORK.



The perfect place to work.

- 1 The 432ZX cab is fully compliant with ROPS/FOPS standards.
- 2 We've fitted a heater, as well as sliding windows on both sides of the cab so that operators stay as comfortable, alert and, therefore, productive as possible.
- 3 The 432ZX's servo loader controls are extremely precise, and provide smooth, low effort, fatigue-free operation.
- 4 All-round visibility is excellent; a modern rear mounted cab design, large glass areas and narrow pillars give a clear view, particularly to the front shovel.
- 5 Large inclined steps and ergonomic grab handles make cab access safe and easy.



PRODUCTIVITY UP, DOWNTIME DOWN.

WE UNDERSTAND THAT YOU NEED YOUR MACHINERY TO SPEND MOST OF ITS WORKING LIFE IN SERVICE, NOT BEING SERVICED. THAT'S WHY WE'VE BUILT THE 432ZX TO GIVE YOU MAXIMUM PRODUCTIVE UPTIME.

Productivity up, downtime down.

The 432ZX has long oil and filter change intervals to keep maintenance to a minimum.

1 Servicing, daily checks and radiator access couldn't be simpler, via fully opening gull-wing type doors.

Remote pressure test points are quick, easy and convenient.

The hydraulic valve block is readily accessible through front access panels.

2 Cab roof rails make glass cleaning and beacon mounting safe and easy for the operator.

3 A conveniently placed toolbox provides safe and secure storage.

4 Ground level daily checks and eye level fluid gauges provide vital information quickly and easily.

5 The 432ZX has oil-immersed disc brakes for a long, virtually maintenance free lifespan.

6 Our single face cooling pack makes it simple to clean and maintain the cooling matrix.

	SERVICE INTERVALS
Engine oil and oil filter	Every 500 hours
Hydraulic oil	Every 2000 hours
Hydraulic filter	Every 500 hours
Transmission filter	Every 1000 hours
Transmission oil	Every 1000 hours
Axle oil	Every 1000 hours

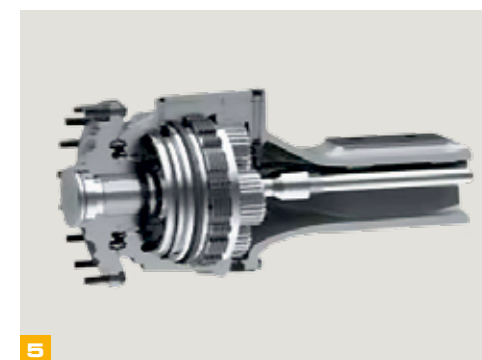

VALUE ADDED.

JCB'S WORLDWIDE CUSTOMER SUPPORT IS FIRST CLASS. WHATEVER YOU NEED AND WHEREVER YOU ARE, WE'LL BE AVAILABLE QUICKLY AND EFFICIENTLY TO HELP MAKE SURE YOUR MACHINERY IS PERFORMING TO ITS FULL POTENTIAL.



1

1 Our Technical Support Service provides instant access to factory expertise, day or night, while our Finance and Insurance teams are always on hand to provide fast, flexible, competitive quotes.

2 The global network of JCB Parts Centres is another model of efficiency; with 16 regional bases, we can deliver around 95% of all parts anywhere in the world within 24 hours. Our genuine JCB parts are designed to work in perfect harmony with your machine for optimum performance and productivity.



2

3 JCB Assetcare offers comprehensive extended warranties and service agreements, as well as service-only or repair and maintenance contracts. Irrespective of what you opt for, our Maintenance teams around the world charge competitive labour rates, and offer non-obligation quotations as well as fast, efficient insurance repair work.



3

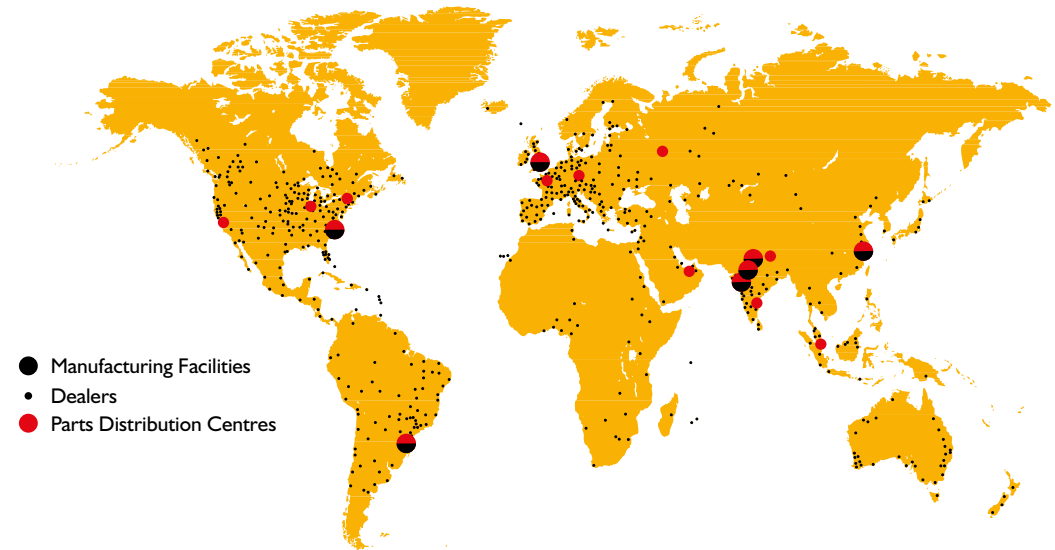

Note: JCB ASSETCARE may not be available in your region, so please check with your local dealer.

STATIC DIMENSIONS

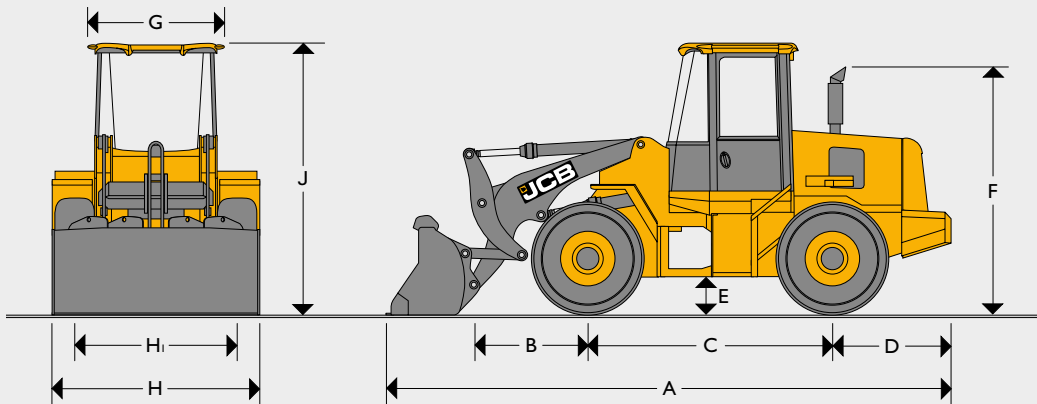

Machine model		432ZX
A	Overall length with standard bucket	mm 7163
B	Axle to pivot pin	mm 1096
C	Wheelbase	mm 3000
D	Axle to counterweight	mm 1788
E	Minimum ground clearance	mm 390
F	Height over exhaust	mm 2985
G	Width over cab	mm 1680
H	Width over tyres	mm 2400
Hi	Wheel track	mm 1955
J	Height over cab	mm 3250

ENGINE

Model	Cummins 6B TA-A 5.9 C-150C
Type	4 stroke, direct injection
Aspiration	Turbo charged
No. of cylinders	6
Bore/Stroke	102 x 120mm
Displacement	5.9 Litres
Gross Power	112kW (150hp)
Max. Torque	650Nm @1500rpm
Emission	BS III conforms to CMVR norms

SERVICE CAPACITIES

Hydraulic system	litres	210
Fuel tank	litres	210
Engine coolant	litres	40
Engine oil	litres	15
Transmission	litres	30
Rear axle	litres	26
Front axle	litres	26

SPEED

Maximum speeds in each gear	Forward (kph)	Reverse (kph)
1st	6.7	7.0
2nd	12.2	12.8
3rd	23.2	24.3
4th	37.5	-

PERFORMANCE DIMENSIONS

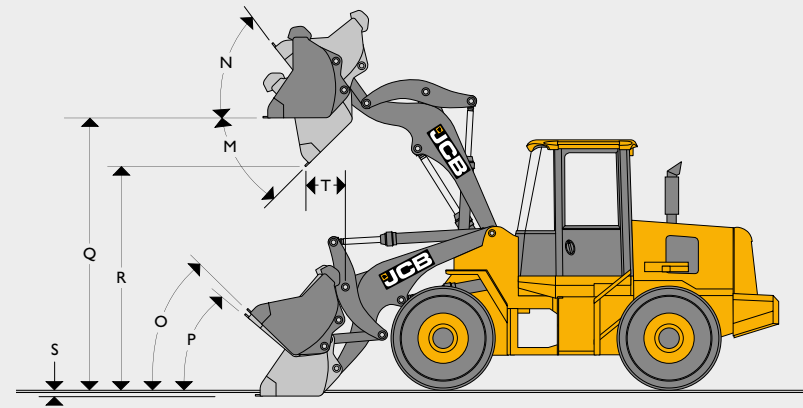

M	Dump angle maximum	45°	Bucket width	mm	2700
N	Roll back angle at full height	52°	Bucket weight - with tooth	kg	950
O	Roll back angle at carry	44°	Payload	kg	3650
P	Roll back angle at ground level	35°	Tipping load straight	kg	8738
Q	Load over height	mm 3571	Tipping load full turn	kg	7618
R	Dump height (45° dump)	mm 2800	Maximum breakout force	kgf	12352
S	Dig depth	mm 77	Reach maximum (45° Dump)	mm	1930
T	Reach at dump height	mm 1183	Pin height maximum	mm	3810
	Bucket capacity (SAE heaped)	m ³ 2.1	Inside turn radius	mm	2900
	Bucket capacity (struck)	m ³ 1.75	Maximum turn radius	mm	5790

BRAKES

Service: Hydraulic power braking on all wheels operating pressure 65 bar. Dual circuit with accumulator back-up. Outboard mounted, oil immersed, multi-plate disc brakes **Parking:** Mechanical disc type operating on transmission output shaft.

STEERING

Priority steer hydraulic system with integrated priority valve operating at 170-180 bar. Adjustable steering column. Steering angle: $\pm 40^\circ$

TYRES

Standard: 20.5 x 20 PR

ELECTRICS

24 volt negative ground system, 45 amp alternator with 2 X110 AH low maintenance batteries. Ignition key start/stop. Other electrical equipment includes 4 front and 2 rear work lights, rear registration plate lights, parking lights, direction indicators, reverse lights and alarm. Relays and fuses are well identified and conveniently located on side console.

HYDRAULICS

Twin gear pump directly mounted on transmission. Twin spool remote mounted valve block with float. Main services are servo actuated from hydraulic remote lever (joystick) and loader control through accumulator back-up hydraulic supply unit. **System pressure:** 245 bar **Pump displacement:** 88.5 cc/rev **Pump flow:** 182 lpm

TRANSMISSION

4-wheel drive, automatic powershift transmission, electrically operated selector and gear change incorporating a speed inhibitor and modulation for responsive on-the-move direction and ratio changes. Single stage integral torque converter **Type:** Automatic Powershift **Make and model:** ZF4WG-160 **Gradeability:** 55.9% (30°).

AXLES

Type: Epicyclic hub reduction **Make and model:** Graziano PR10 front and rear **Overall axle ratio:** 20.197:1 **Rear axle oscillations:** $\pm 21^\circ$

OPTIONS

2.1, 2.3, 2.7 cu.m³ shovels, dozer blade.



ONE COMPANY, OVER 300 MACHINES.

Your nearest JCB dealer

432ZX Wheeled Loading Shovel

Operating weight: 12,100kg Gross engine power: 112kw (150hp) Full turn tipping load: 7,618 kg
 Standard shovel capacity: 2.1m³

JCB Sales Limited, Rokeceter, Staffordshire, United Kingdom ST14 5JP.
 Tel: +44 (0)1889 590312 Email: salesinfo@jcb.com
 Download the very latest information on this product range at: www.jcb.com

©2009 JCB Sales. All rights reserved. No part of this publication may be reproduced, stored in a retrieval system, or transmitted in any form or by any other means, electronic, mechanical, photocopying or otherwise, without prior permission from JCB Sales. All references in this publication to operating weights, sizes, capacities and other performance measurements are provided for guidance only and may vary dependant upon the exact specification of machine. They should not therefore be relied upon in relation to suitability for a particular application. Guidance and advice should always be sought from your JCB Dealer. JCB reserves the right to change specifications without notice. Illustrations and specifications shown may include optional equipment and accessories. The JCB logo is a registered trademark of J C Bamford Excavators Ltd.

