



BD 202 HL



BD 202 HL



www.ausa.com

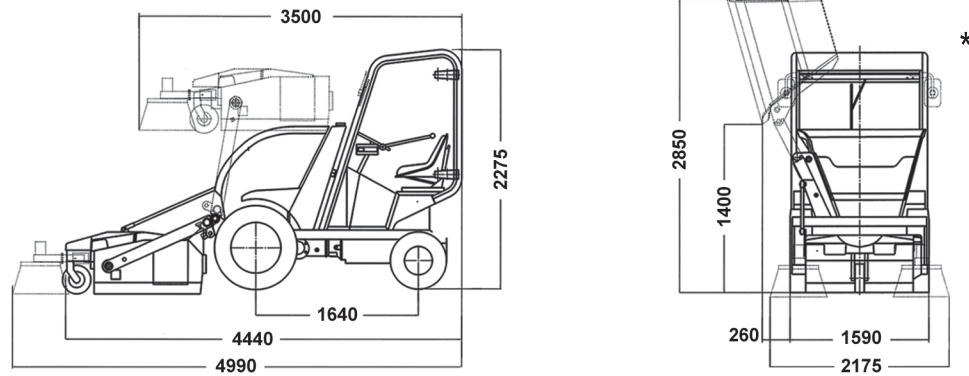

TECHNICAL SPECIFICATIONS

BD 202 HL

Hopper capacity		900 l
Sweeper attachment capacity		245 l
Elevation and unloading of the sweeper attachment		Hydraulic
Hopper unloading height		1500 mm
Engine	Diesel	Kubota V1505
	Power s/DIN 6271 (kw / HP)	22.9 / 30.8 (2600rpm)
	N° cylinders	4
	Coolant	Liquid
Traction		4x4 Permanent Compen® System
Transmission		2-Speed Hydrostatic ratios. Electrical gear inverter
Ignition		Electrical
Speed max.		20 Km/h
Sweep width		from 1720 to 2630 mm
Side-shift		400 mm
Recomended sweep speed		5 Km/h
Central brush width		1200 mm
Central brush diameter		450 mm
Side brush diameter		850 mm
Unloaded weight (with full tanks)		2300 Kg
Maximum slope	Under full load	42%
	Sweeping	20%
Tyres	Front	10.0 / 80 - 12" TL (10PR)
	Rear	10.0 / 80 - 12" TL (10PR)
Steering		Hydraulic. Working Service 80 bar
External turning circle		4180 mm
Tank capacity	Fuel	40 l
	Hydraulic oil	40 l
	Water supply for sprinkling	350 l
Water pump		Electric of 12.5 l/min
Total water spraying width		2500 mm
Service brake		Oil immersed multidisc
Parking brake		Oil immersed multidisc
Hydraulic circuit		Double gear pump. Delivery 8cc for steering and 12cc for services. Service pressure 190 bar

STANDARD EQUIPMENT

- Great comfort and ergonomic driver seat
- Rotating beacon
- Audible reverse warning
- Seat belt
- Anti vandal System
- ROPS / FOPS protective arch
- Windscreen with wiper
- Approved lighting equipment
- Rear-view mirror
- Water flow control

OPTIONAL EQUIPMENT

- Self-loading bucket, capacity 130l, easily interchangeable with the sweeping equipment
- Additional passenger seat
- Soundproof closed cabin with heater
- Steel snow-blade width of 2,000 mm, with anti-obstacles security system
- Tilting hydraulically on both sides +/- 30°
- Automatic cover on waste cargo box, by means of an hydraulic cylinder controlled with the joystic. Safety system against shocks, opening on cargo box with transparent plastic to control the level or waste, managing the collecting and transporting of waste on more ecological and efficient manner specially when picking up leaves
- High water pressure street cleaning equipment with pipe and gun, water pressure 140 bar
- Special compartment for cleaning accessories as blowers, rakes, broom, etc.
- Air conditioning
- Radio-CD & MP3 + Bluetooth
- Equipment for low pressure watering